

6-36Kv Medium Voltage Underground Power Cables

XLPE insulated cables



 Nexans

Cable solutions to ensure the reliability of your energy network



With energy as the basis of its development, Nexans, the worldwide leader in Group is a global player in the infrastructure, industry, building and Local Area transport and telecom networks to shipbuilding, oil and gas, nuclear p



the cable industry, offers an extensive range of cables and cabling systems. The Network markets. Nexans addresses a series of market segments from energy, power, automotive, electronics, aeronautics, handling and automation.

Contents



CABLE

	page
● Cable power circuit design	7
■ Conductor	7-8
■ Conductor screen	8
■ Insulation	8
■ Insulation screen	8-9
■ Metallic screen	9-10
■ Outer protective sheath	10-11
● Table of cable elements	12
● Cable constructions	13
● Cable drums	14
● Cable tests following production	15



ACCESSORIES

● Introduction	16
● Connectors and lugs	16
● Electrical fields	17
● Terminations	17
■ Leakage path and creepage distance	17-18
■ Slip-on termination	18
■ Heat-shrinkable termination	18
■ Cold-shrinkable termination	18
● Screened, separable connectors	18-19
● Surge arresters	19
● Joints	19
■ Transition joints	19



INSTALLATION

● Cable Drum Handling	20
● Installation Environment	20
● Type of installation	21
● Installation Temperature	22
● Pulling Forces	23
● Bending Radii	23
● Cable Support Spacing	23
● Special Civil Engineering Works	24
● Tests after installation	24
● Current ratings	25



TECHNICAL SPECIFICATIONS

● Introduction	26
● 3.8/6.6 (7.2) kv Three Core armoured copper conductors	27
● 6.35/11 (12) kv Triplex / Single Core unarmoured copper conductors	28
● 6.35/11 (12) kv Triplex / Single Core unarmoured aluminium conductors	29
● 6.35/11 (12) kv Three Core unarmoured copper conductors	30
● 6.35/11 (12) k Three Core unarmoured aluminium conductors	31
● 6.35/11 (12) kv Single Core armoured copper conductors	32
● 6.35/11 (12) kv Single Core armoured aluminium conductors	33
● 6.35/11 (12) kv Three Core armoured copper conductors	34
● 6.35/11 (12) kv Three Core armoured aluminium conductors	35
● 8.7/15 (17.5) kv Single Core armoured copper conductors	36
● 8.7/15 (17.5) kv Three Core armoured copper conductors	37
● 12/20 (22) kv Single Core copper unarmoured conductors	38
● 12/20 (22) kv Single Core armoured copper conductors	39
● 12/20 (22) kv Three Core armoured copper conductors	40
● 19/33 (36) kv Single Core unarmoured copper conductors	41
● 19/33 (36) kv Single Core unarmoured aluminium conductors	42
● 19/33 (36) kv Single Core armoured copper conductors	43
● 19/33 (36) kv Three Core armoured copper conductors	44

All the data given in this brochure is communicated for information only and is not legally binding to Nexans

General power circuit design

This brochure deals with underground power circuits featuring three-phase AC voltage insulated cable with a rated voltage between 6.6kV and 36kV. These lines are mainly used in a distribution network for electrical power, connecting local substations or small generating units such as wind turbines to the main grid supply point, or for connecting plant in industrial processes which require large amounts of power. Medium voltage insulated cables may also be used in conjunction with bare overhead lines in networks.

The voltage of a circuit is designated in accordance with the following principles:

Example:

U_o/U (U_m) : 19/33 (36)

U_o = 19kV phase to ground voltage

U = 33kV rated phase to phase voltage

U_m = 36kV highest permissible voltage of the grid

Phase-to-ground voltage, designated U_o is the effective value of the voltage between the conductor and the ground or metallic screen

Rated voltage, designated U, is the effective phase to phase voltage.

Maximum voltage, designated U_m, is the permissible highest voltage for which the equipment is specified.

A **medium voltage insulated cable** circuit consists of three single core cables or one **three core cable** with **terminations** at each end to connect it to the transformer or switchgear in the network.

The terminations may be outdoor, mounted on a pole or indoor type in a screened enclosure.

When the length of the circuit exceeds the capacity of a cable drum, **joints** are used to connect the lengths together.

To ensure the cable is fixed firmly in place under any mechanical or electrical stress, **cable cleats** will be used to fix it to surfaces.

In addition, the **basic impulse level** (BIL) determines the maximum capacity any equipment will withstand if subjected to a lightning strike.

The rated voltage of a medium voltage cable is determined by the thickness of the insulation. Unlike high voltage cables which do not have set values for the insulation thickness, the thickness of the insulation around a conductor in a medium voltage cable is set at specified levels according to international standards.

The general voltage levels covered by this publication are:

U _o (kV)	U (kV)	U _m (kV)	BIL (kV)	Insulation Thickness (minimum average)
3.8	6.6	7.2	60	2.5 – 3.2 mm*
6.35	11	12	95	3.4 mm
8.7	15	17.5	120	4.5 mm
12.7	20	24	144	5.5 mm
19	33	36	194	8.0 mm



The cable

The structure of medium voltage cables with extruded insulation will always involve the following items:

CONDUCTOR CORE

For medium voltage cables, conductors are rated by their effective cross sectional area in mm^2 – this indicates how much current can flow through the conductor – i.e. the larger the conductor, the greater the amount of current.

Conductors for medium voltage are normally used in the range from 35mm^2 up to 1000mm^2 and are usually either compacted stranded or solid construction.

In some three core designs, sector shaped conductors can be used to reduce the overall diameter of the cable.

As copper has a lower electrical resistance than aluminium, it is a more efficient conductor of electrical current and requires smaller cross sections to carry the same amount of power as an aluminium conductor. For example, a copper conductor of 300mm^2 cross section can carry approx 670 Amps in a buried installation, yet an aluminium conductor will carry only approx 525 Amps under the same conditions. It would require a larger cross section of 500mm^2 to achieve the same rating.

However, aluminium is substantially lighter than copper and therefore has the advantage of enabling longer lengths to be safely handled,

meaning less jointing. Also, aluminium is generally lower in price than copper on the metals commodity markets making it more economical per amp than copper.

Therefore, aluminium conductors are usually used for medium voltage distribution networks requiring long distances and extensive cabling, whereas copper cables are used for short links in substations and industrial installations where smaller cables or higher power transmitting properties are required.

Stranded conductors consist of several layers of spiral wound wires which are compacted together. They are normally constructed as Class 2 according to IEC 60228 (BS EN 60228), although it is possible to use Class 5 flexible stranded conductors in conjunction with Ethylene Propylene Rubber (EPR) insulation for short leads.

As stranded conductors will have spaces in the interces, there may be a requirement to longitudinally water-block the conductor by using water swellable powders or tapes in the conductor construction. These materials will block the travel of any moisture through the conductor if it was to enter at a termination or joint position. Aluminium conductors are usually water-blocked to prevent the corrosive reaction with water, but copper cables are normally not specified with these materials unless the cable is to be used in very wet conditions, e.g. subsea cables.

Aluminium solid conductors, by their design are water-blocked and usually are of slightly reduced diameter than the equivalent stranded versions. However, it is usually too difficult to handle these conductors for terminating and jointing for cross sections above 300mm^2 .

Compact round conductors, composed of several layers of concentric spiral-wound wires.

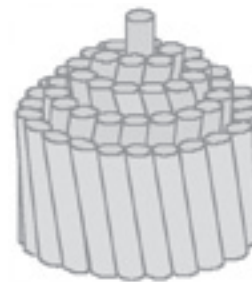

The cable

Around the conductor, it is necessary to provide insulation to prevent electrical short circuits. In medium voltage cables there are two main types of insulation material:

- XLPE – Cross linked Polyethylene – the most common material for MV cables today.
- EPR – Ethylene Propene Rubber – more flexible than XLPE but not as efficient at reducing losses in circuits as XLPE. Cables used in marine and offshore applications are normally constructed with EPR insulation.

Note:

As the most common type of insulation, all data provided in this handbook is based on cables with XLPE insulation.

According to the requirements of various standards, cables for medium and high voltages require three specific layers of extruded material around the conductor to form the insulation system.

These layers are known as the conductor screen, insulation and insulation screen and are normally extruded in one operation, known as triple pass, or triple extruded.

SEMI-CONDUCTOR SCREEN ON THE CONDUCTOR (KNOWN AS THE “CONDUCTOR SCREEN”)

This consists of a layer of black semi-conductive cross-linked compound, usually less than 1.0mm

in thickness, which is the interface between the conductor and the insulation.

The external surfaces of the conductor may not be smooth, particularly for stranded conductors, so this layer provides a smooth surface at the same potential as the conductor to keep the electric field consistent all the way around the surface. Without this layer, any small peaks or troughs could cause concentrations of electrical energy which could create small arcs, and over time could erode the insulation layer and cause failure of the cable.

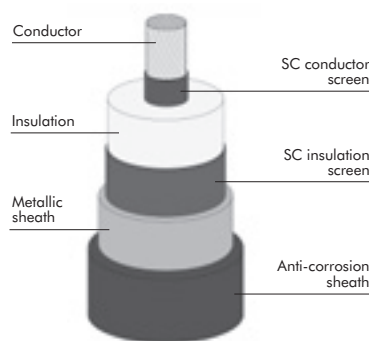

Cable components

The conductor screen is fully bonded to the adjacent insulation layer.

INSULATION

As its name suggests, the insulation insulates the conductor at voltage from the outer screens which are at ground potential. The insulation must be of sufficient thickness to withstand the electric field under the rated and transient operating conditions – see the table on insulation thickness in previous section.

Due to the cross linking structure of XLPE, it enables the cables to run safely at higher temperatures than thermoplastic materials such as PVC, and therefore carry more current. The continuous current ratings found in this document are based on conductor temperatures of 90°C which is the accepted maximum normal working temperature for cables in service.

In a short circuit, the XLPE can accommodate conductor temperatures of up to 250°C.

In three core medium voltage cables, the insulation is left in its natural colour and is not used for core identification – this is achieved by either printing on the insulation screen or colour coded tubes between the cores or marker tapes.

SEMI-CONDUCTIVE SCREEN ON INSULATION (KNOWN AS THE “INSULATION SCREEN”)

This layer has a similar function to the conductor screen: it provides a smooth transition from the insulating medium to the grounded metallic screen.

This is a layer of black cross linked semi conductive compound of approx 1mm thickness and is either fully bonded to the insulation layer, or can be “cold strippable” by hand.

When terminating or jointing the cables, it is necessary to remove a part of the insulation screen – for fully bonded insulation screens this

The cable



requires a special rotary stripping tool with blades at pre-set depths to consistently remove the black semi-conductive layer without removing the insulation.

Cold Strippable screens (sometimes referred to as “easy strippable”) do not require such tools and can be peeled off the insulation leaving a clean layer of insulation.

However, it can be more difficult to make a smooth tapered transition between screen and insulation with the cold strippable screen and special care has to be taken when using knives or other tools to achieve this.

The rotary stripping tools for bonded screens can leave a smooth tapered edge at the end of the screen which reduces any electrical stress at this transition point.

Normally, three core cables are specified with cold strippable screens as it is difficult to get the rotary tools in between the adjacent cores. Single cores, particularly at the higher voltage levels tend to be fully bonded.

METALLIC SCREEN

The main function of the metallic screen is to nullify the electric field outside of the cable – it acts as a second electrode of the capacitor formed by the cable. The screen needs to connect to earth at least at one point along the route.

The capacitive charging current and induced circulating currents which are generated under normal operating conditions will be drained away through the screen.

The screen also drains the zero-sequence short circuit currents under fault conditions; this function is used to determine the required size of the metallic screen.

The second function of the metallic screen is to form a radial barrier to prevent humidity from penetrating the cable insulation system.

The extruded insulation system should not be exposed to humidity. When humidity and a strong electric field are present together, the insulation deteriorates by what is called water-treeing, which can eventually cause the insulation to fail.

Note:

In the case of an overhead line, the insulation is formed by the air between the bare conductor and the ground.

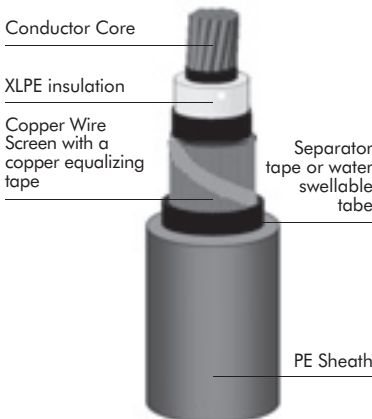

Copper Wire Screen with equalizing tape

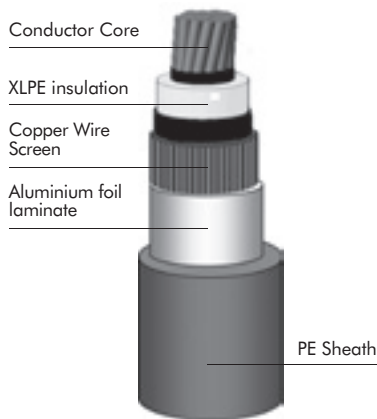

Laminate foil sheath with additional copper wires

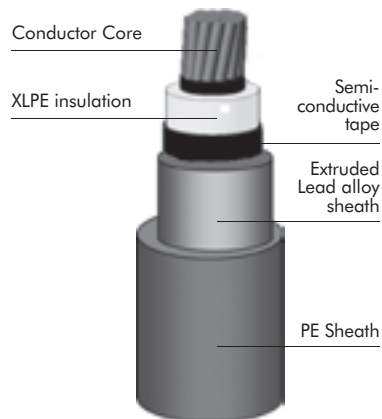

Lead Sheath

The cable

DIFFERENT TYPES OF METALLIC SCREEN

Concentric Copper Wire screens (with optional equalising tape).

Advantages:

- Lightweight and cost effective design.
- High short-circuit capacity.
- Easy to terminate.

Drawbacks:

- Low resistance of screen may necessitate need for special screen connections to limit the circulating current losses.
- Does not form a complete moisture barrier (unless water swellable tapes are used under and/or over the copper wires).

Aluminium foil laminate

Advantages:

- Lightweight and cost effective design.
- Moisture proof radial barrier.

Drawbacks:

- Low short circuit capacity.
- More difficult to terminate – requires special screen connections.

Extruded lead alloy sheath

Advantages:

- Waterproofing guaranteed by the manufacturing process.

- Excellent resistance to corrosion and hydrocarbons (suitable for oil and gas plants).

Drawbacks:

- Heavy and expensive.
- Lead is a toxic metal whose use is being restricted in some countries.
- Limited capacity for short circuits.

Other metallic screen constructions such as copper tape screens can be used, also combinations of the mentioned designs such as lead sheath + copper wires, or aluminium foil laminate + copper wires can be used to increase the short circuit rating of the cables.

ANTI-CORROSION PROTECTIVE JACKET (OR SHEATH)

The outer sheath has a number of functions:

- It insulates the metallic screen from the ground (particularly for lines with high circulating currents)
- It protects the metal components of the screen from humidity and corrosion.
- It protects the cable from the mechanical stresses encountered during installation and service.

It can also be tailored to withstand specific effects such as termite attack, resistance to hydrocarbons etc.

There are two main materials used for cable sheaths: Poly-Vinyl Chloride (PVC) and polyethylene (PE). The PE material used for sheaths can be medium density (MDPE) or Linear low density (LLDPE), or when a very strong sheath is required, high density (HDPE).

PVC is used mainly for cables with wire armouring or lead sheaths as it is softer than PE. One of the advantages of PVC is its fire retardant properties, although the toxic and corrosive fumes released are prohibited by many users.

The use of sheaths with increased fire properties is becoming more prevalent. Cables installed in tunnels and confined spaces are required to reduce the spread of fires and give off no harmful and corrosive gases to protect personnel and equipment.

For this application, HFFR (Halogen-Free Fire Retardant) materials are used in preference to PVC or PE.

These materials however have mechanical properties that are inferior to those of PVC/PE, and are more costly. They should be reserved for installations or parts of installations where the fire protection is required.



The cable

A semi-conductive layer can be specified to enable sheath testing to be carried out following installation. The thin layer of semi-conductive compound is extruded onto the PE sheath material along the entire length of the cable.

By connecting a DC voltage between the metallic screen and the outer layer and measuring the resistance, any perforations in the sheath will be apparent by a lower than expected reading. More details on the sheath integrity test are described in the installation section.

The outer sheath is also where the relevant marking to identify the type, place of manufacture and date of manufacture and other information are placed. The information is either indented or embossed (raised characters).

If required, metre marking and the phase identification (for single core, triplexed cables) can be marked with ink jet.

For the UK market, it is accepted convention that medium voltage cables up to and including 22kv have red outer sheaths, and 33kV cables have black coloured sheaths.

Ongoing work on sheath materials in Nexans plants is developing new options, including HFFR materials which are as strong as PE or PVC versions. Also being developed are cables with dual walled sheaths with air gaps in the middle to act as shock absorbers under impact. This will enable cables to be buried underground in conditions which normally require ducting or added protection.

The cable

SUMMARY OF THE CABLE ELEMENTS

Item	Function	Composition
Conductor	<ul style="list-style-type: none"> • to carry current - under normal operating conditions - under overload operating conditions - under short-circuit operating conditions • to withstand pulling stresses during cable laying 	<p>S < 1000mm² (copper or aluminium) Compacted round stranded conductors</p> <p>S < 400mm² (aluminium) Round solid conductors</p>
Internal semi-conductor	<ul style="list-style-type: none"> • To prevent concentration of electric field at the interface between the insulation and the internal semi-conductor • To ensure close contact with the insulation. To smooth the electric field at the conductor. 	XLPE semi-conducting shield
Insulation	<ul style="list-style-type: none"> • To withstand the various voltage field stresses during the cable service life: - rated voltage - lightning overvoltage - switching overvoltage 	<p>XLPE insulation</p> <p>The internal and external semi-conducting layers and the insulation are co-extruded within the same head.</p>
External semi-conductor	To ensure close contact between the insulation and the screen. To prevent concentration of electric field at the interface between the insulation and the external semi-conductor	XLPE semi-conducting shield
Metallic screen	To provide: <ul style="list-style-type: none"> • An electric screen (no electric field outside the cable) • Radial waterproofing (to avoid contact between the insulation and water) • An active conductor for the capacitive and zero-sequence short-circuit current • A contribution to mechanical protection 	<ul style="list-style-type: none"> • Extruded lead alloy, or • Copper wire screen (with optional helical equalising tape) • Welded aluminium screen bonded to a PE jacket • Combination of copper wires and lead sheath • Combination of copper wires and aluminium foil laminate • Copper tape screens and wire armouring • Copper foil laminate
Outer protective sheath	<ul style="list-style-type: none"> • To insulate the metallic screen from the surrounding medium • To protect the metallic screen from corrosion • To contribute to mechanical protection • To reduce the contribution of cables to fire propagation 	<p>Insulating sheath</p> <ul style="list-style-type: none"> • Possibility of semi-conducting layer for dielectric tests • Polyethylene jacket • PVC jacket • HFFR jacket

The cable



CABLE CONSTRUCTIONS

Medium voltage cable circuits consist of three single core cables, or one three core cable. In conjunction with the elements described so far (conductor, conductor screen, insulation, insulation screen, metallic screen and outer jacket), additional materials as follows are used to make up different constructions of the cable:

- **Bedding** – fillers and/or tubes to build up circular profile in three core cables.
- **Separator tapes** – provides a barrier between layers, e.g. to prevent any sticking during extrusion.
- **Conductive tapes** – to bind three cores together in three core cables.
- **Water swellable tapes** – to provide a barrier for moisture ingress under the sheath.
- **Armouring** – to provide mechanical protection and to carry away short circuit current.

The following are the most common constructions for medium voltage:

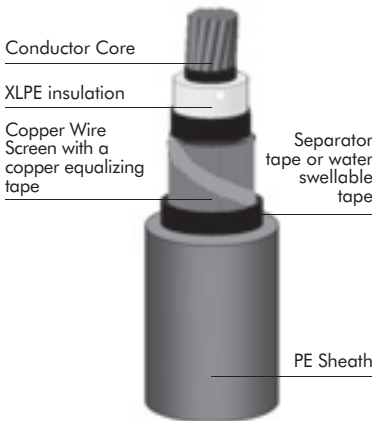

Copper Wire Screen with equalizing tape

A slight variant of the single core, copper wire screened cable is to lay up three single cores on a drum – this reduces installation time as all three cores can be pulled into the ground/duct at the same time. This is known as Triplex configuration.



Single core cable in triplex formation

For use in environments where hydrocarbons are present, lead sheathed versions are used to provide a chemical resistant barrier.

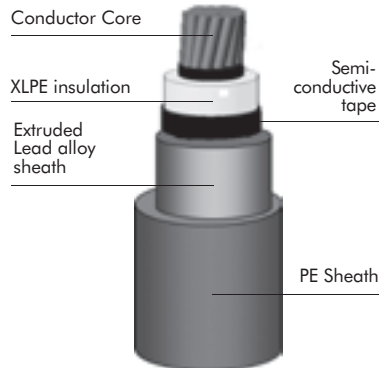

Lead Sheath

Where cables are run above ground in cable trays or ladders, or where there is a risk of mechanical damage, then wire armoured versions are used. For three core cables, galvanised steel wires are helically wound around the screens. For single core versions, aluminium armour wires are used as it is not possible to use steel as this will act as a transformer in A.C. cables and generate harmful voltages in the armouring; therefore a non-ferrous material has to be used.

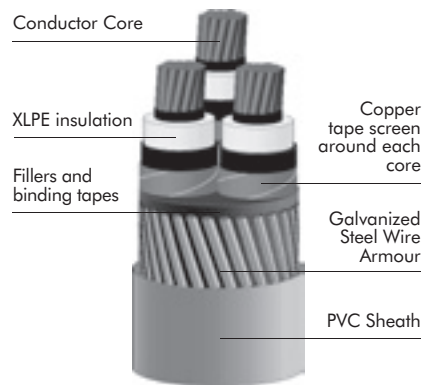

3 core SWA cable

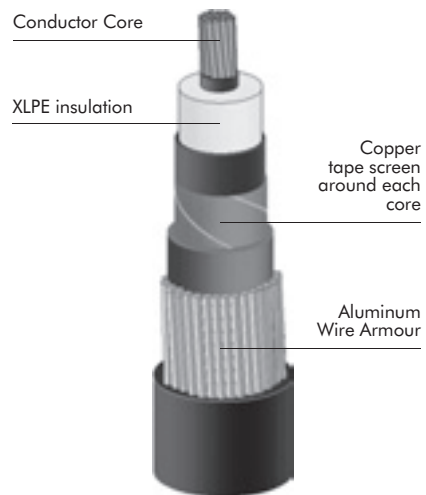

1 core AWA cable

The cable

CABLE DRUMS

It is generally the cable drum which dictates the maximum length of cable that can be supplied, either due to the maximum weight of the cable and drum which can be safely transported, or more often, the maximum size of the drum which is either available or can be transported and handled safely.

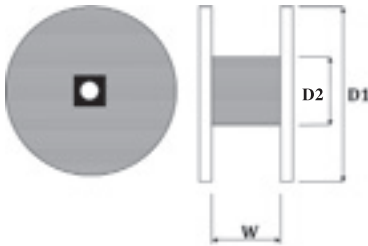

Medium voltage cables are usually supplied on timber drums which can be returned for re-use after installation. The correct selection of drum for a cable is important to prevent damage in transit (if insufficient clearance is left around the flanges) and to enable ease of installation by ensuring the drum barrel diameter is sufficiently large enough not to damage the cable by bending too tightly around the barrel.

The table (top right) gives the minimum barrel diameter for each cable type:

The exact dimensions of drums supplied can vary slightly depending upon the manufacturing plant's designs, however the table (bottom right) gives some typical dimensions and approximate capacity based on the cable's overall diameter.

Type of screen and cores	Minimum barrel diameter (expressed as multiple of the cable overall diameter D)
Copper wire screen, single core	20 x D
Copper wire screen, three core	16 x D
Armoured, single core	16 x D
Armoured, three core	14 x D
Lead sheathed, un-armoured single core	24 x D
Lead sheathed, armoured three core	16 x D
Aluminium foil laminate, single core	24 x D
Aluminium foil laminate, three core	12 x D

D1 = Flange Diameter (mm)	1400	1650	1800	1900	2100	2200	2400	2600	2900
W = Useful width (mm)	770	1000	1000	1000	1000	1000	1000	1000	1280
D2 = Barrel diameter (mm)	610	750	1000	1000	1000	1200	1300	1600	1900
Approx empty weight (kg)	170	285	425	460	530	640	770	950	1400
Ground clearance (mm)	50	50	50	50	50	50	50	50	50
Approx volume (m³)	1.947	2.81	4.184	4.491	5.565	6.087	7.598	8.526	13.5
Cable diameter (mm)	Approx capacity in metres								
20	1800	3000	3300						
25	1100	2200	2300	2700	3400				
30	775	1480	1640	1800	3090	2330	2480	3090	
35	540	1050	1140	1290	1540	1640	2300	2050	3060
40	410	850	910	1040	1260	1350	1770	1680	2490
45		580	700	710	1010	1080	1290	1345	1990
50		540	550	660	820	875	1060	1090	1590
55			420	510	650	690	850	960	1280
60			380	380	500	530	660	660	1010
65			290	360	390	415	630	525	775
70			250	270	360	390	500	490	725
75					340	360	475	375	700
80					250	270	360	340	535
85						250	340	310	500
90							270	310	475
95								220	340
100								220	317



The cable

CABLE TESTS FOLLOWING PRODUCTION

The tests carried out on cables can be grouped into three categories:

1. Routine tests
2. Sample tests
3. Type tests

The actual details for each test vary according to the specification followed (e.g IEC 60502 or BS 7870), however they generally include the following:

Routine tests

These non-destructive tests are normally carried out on each manufactured length of cable, and include:

- Measurement of electrical resistance of conductors
- Partial discharge test
- Voltage tests, typically a test of $4 \times U_0$ between core and metallic screen for 15 minutes
- D.C. voltage test on sheath

Sample tests

These tests, which can be destructive, are carried out on one length or drum from a manufacturing run:

- Conductor examination
- Dimensions check
- 4 hour voltage test at $4 \times U_0$
- Hot set test (on XLPE insulation)

Type tests

These tests are carried out to validate the cable design, materials and/or production process and are done usually once at the beginning of the supply of a particular cable design. The tests can be divided into two categories, electrical and non-electrical:

Electrical Type tests

- Partial discharge test.
- Bending test.
- $\tan \sigma$ measurement.
- Heat cycle test followed by partial discharge measurement.
- Impulse withstand voltage test.
- Long term voltage test.

Non-Electrical type tests:

- Dimension checks.
- Mechanical properties before and after ageing (tensile strength and elongation).
- Thermoplastic properties (hot pressure tests and behaviour at low temperatures).
- Other tests.

The cables manufactured by Nexans' sites are usually tested in accordance with international standards IEC 60502. Test programmes in accordance with national standards such as BS 7870 or BS 6622 or even client specific specifications may also be performed.

Accessories

Accessories are used to join power cables to each other or to connect power cables to other equipment.

The medium voltage network system, including the cable and its accessories, has two functions: the dielectric and the current function. The current function transmits the power and the dielectric function insulates this system.

CONNECTORS AND LUGS

Connectors and lugs are used to connect conductors with each other or to connect them to other parts of the installation. In addition to the nominal current, these connectors must be able to carry specified short circuit currents. They have been designed taking into account the thermal and mechanical stresses at the connecting point together with the nominal and short circuit currents.

Cable lug

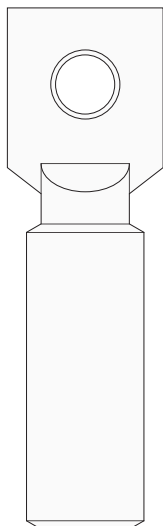

General requirements for connector

- as compact as possible.
- low and constant ohm resistance to avoid voltage drops and to keep heating as low as possible.
- sufficient mechanical resistance to accept the mechanical forces.
- corrosion resistance.
- long life expectancy, will not wear in case of overcharge or short circuit.
- easy and reliable installation.
- able to use with different conductor materials, and no need for surveillance.

Heating modifies the behaviour of the cable link, and thus reduces the life expectancy.

Factors that lead to a rise in temperature of a cable connection:

- quality loss.
- thermal capacity.
- heat dissipation.
- thermal radiation.
- convection.

The higher the temperature, the higher the expansion. This leads to a loss of contact force, an increased oxide formation and a loss of contact surface, which again leads to a higher temperature.

The quality of a connection can be improved by:

- a good coordination between the conductor, the connector and the tools.
- a respect for the installation characteristics prescribed by the supplier.
- a thorough cleaning of the contacts and meticulous work.

Mechanical connectors

In recent years the development of mechanical connectors has allowed an increase in their use. The user now has a large range of products, usable in many circumstances.



Mechanical connector

Major advantages include the large field of use and the copper-aluminum compatibility.

Particularities of connectors with shear off bolts:

- a big range of cable sections (only 5 types for 6 mm² up to 630 mm²).
- for use with copper and aluminium conductors.
- easy to install.
- no need for special tools.
- easy release with hexagon socket.
- for all types of conductors.

This will result in less stock and less cost for tooling.

Accessories

Crimped connectors

When using the crimping technique, it is important to note that the products (connectors, ferrules and lugs) must be compatible with the conductor type and the tools used. Each product has a specific standard. The producer must ensure a perfect connection between the different elements. The crimping method must be adapted to the type of conductor and its material.

ELECTRICAL FIELDS

The electrical field control in an accessory depends on the way this field is controlled in the cable.

In paper insulated, belted cables up to 10 kV, there is a common electrical field and a common metallic screen. Due to the higher stresses, there must be greater distances between the phases and the earthing. The electrical field is not directly controlled.

All other medium and high voltage cables have a stress controlling screen. The electrical field is guided by two semi-conductive cylinders, internally and externally to the insulation, and thus becomes very homogeneous.

When connecting cables, the different layers of the medium voltage cable have to be removed. The electrical field distribution is disturbed by removing the metallic and semi-conductive screen. This will lead to partial discharges and in the short or long term to a break down. For this reason it is necessary to fit an electrical field control device

to the cable at voltages higher than 6 kV. These connecting and field controlling devices are called power cable accessories.

Electrical stress control

This is achieved by using a premoulded stress cone (capacitive or geometrical stress control) or a layer of stress distributing material (refractive or resistive stress control). When using geometrical stress control, a semi-conductive cone is installed on the cable prolonging the cable screen.

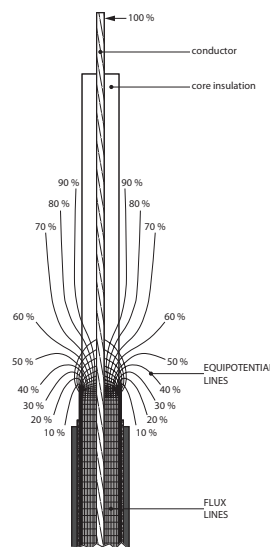

Stress cable

This way, the electrical equipotential lines are diffused and the local stresses are artificially reduced. When using refractive field control, a layer with a high dielectrical constant is put over the cable insulation at the end of the semi-conductive screen. The electrical field is partially pushed back into the insulation by the material chosen for its high dielectrical constant.

The field lines will break out of the cable over a longer distance, giving a lower electrical field inside the accessory.

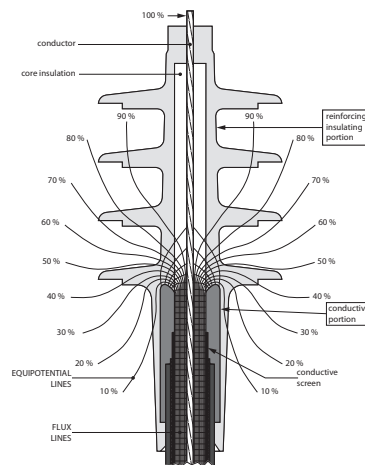

Stress grading termination

TERMINATIONS

Their function is to connect the cable and the other electrical equipment to the network. The termination's main characteristics are: the electrical stress control device (stress cone or stress distribution materials), the leakage distance and the core connectors (cable lugs).

Leakage path and creepage distance

The leakage path is the insulation distance measured between the earthed screen and the cable lug at the top of the termination. It prevents direct conduction via any surrounding fluids (air, gas or oil). The leakage path is equally applicable to indoor terminations and outdoor terminations. Indoors,

Accessories

the leakage path is almost unaffected by environmental factors, but outdoors, the leakage path has to be designed in line with environmental considerations, such as relative humidity, salinity and atmospheric pollution.

The leakage path of a termination is determined by multiplying the IEC 60815 standard pollution factor expressed in mm/kV and the maximum grid voltage. Pollution factor (in mm/kV) x maximum voltage (in kV) = minimum termination leakage path (in mm).

The construction of a termination depends on the voltage, the cable type and its location, eg. indoor and outdoor.

Slip-on termination

Since the 1960s slip-on terminations have been in use. The installation of these premoulded accessories is very easy and simple. Due to their great elasticity they can be installed on all single or three core polymeric cables for use indoors and outdoors. The field control is done by a semi-conductive stress cone inside the (EPDM or silicone) rubber termination housing (capacitive stress control).

Heat-shrinkable termination

These terminations have co-existed for many years with the slip-on terminations. These extruded sleeves are heated by a flame and retract around a cable. The sleeves can contain a hot melt glue that liquefies when heated and adheres to the outer cable sheath. This creates a water tightness that protects the penetration of humidity in the cable.

Cold-shrinkable termination

Cold-shrinkable terminations can be installed on single core and three core cables, for use indoors and outdoors. The electrical field control is done with a stress distributing material (resistive method), which will only slightly increase the outer diameter of the cable. When installing, the pre-expanded termination is put over the prepared cable. The support tubes are then removed and the elastic memory of the outer silicone sleeve pushes the different mastics (for field control and water tightness) firmly on the cable. The outer silicone sleeve will assure a perfect hydrophobicity of the terminations even in polluted areas.



Cold Shrink Termination

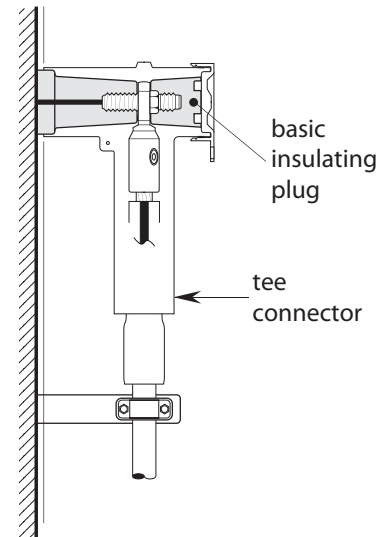

Screened and Separable connectors

SCREENED, SEPARABLE CONNECTORS

A screened connector is an encapsulated, safe to touch termination used to connect dry insulated cable to the epoxy bushings of equipment (transformers, switchgear, motors etc.).

There are many advantages of the screened connector system:

- No minimum clearance distances required: can be installed in compact substations.
- Safe to touch accidentally.
- Maintenance free.
- Quick and easy to install without special tools.

Accessories

- Easy to disconnect.
- Fully watertight.
- Degree of protection IP67: dust tight and immersion in water.
- Resistant to UV, ozone, chemicals, mechanical abuse.
- Temperature range from -30°C to +110°C.
- Offers many test options: capacitive test point, cable test.
- A complete range from 12 kV up to 42 kV.
- Can be used outdoors without cable box.

For use in potentially explosive atmospheres, ATEX certified systems are available. Manufacturers who apply the provisions of this directive can sell without any further requirements with respect to the risks covered. The directive covers a large range of equipment, including those used on fixed offshore platforms, in petrochemical plants, mines, flour mills and other areas where a potential explosive atmosphere may be present.

The outer cone system (as described in CENELEC 50180 and 50181) has several standard interfaces for the different current classes:

- Interface A: up to 250 A with a plug-in connection.
- Interface B: up to 400 A with a plug-in connection.
- Interface C: up to 630 A (1250 A) with a bolted connection.
- Interface D: up to 800 A with a bolted connection.

SURGE ARRESTERS

For installations that need to be protected against overvoltages from lightning or switching surges, there are surge arresters containing zinc oxide blocks. They are installed on the equipment itself or on the cable connection.

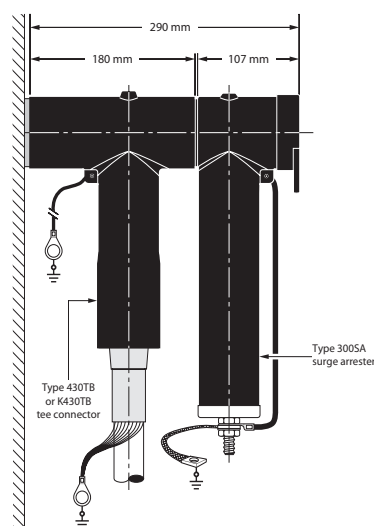

300PB – SA Surge Arrestor

JOINTS

Medium voltage joints are used for jointing screened polymeric cable to be laid in air or directly buried. The conception and construction of a joint depends on the voltage, the construction of the cable and the electro-dynamic forces during a short circuit. The components of the joint have to connect the conductors and to recreate the insulation. In premoulded joints the different functions – insulation, field control and mechanical protection – are often integrated.

Transition joints

Transition joints are for jointing paper-insulated cables to polymeric cables. Often a hybrid transition solution is used. This hybrid transition joint combines cold-shrinkable and heat-shrinkable technology. The heat-shrinkable technology is used for re-insulating and oil barrier purposes. The cold-shrinkable technology is used for the actual jointing of the three phases. These joints are fully screened and submersible.

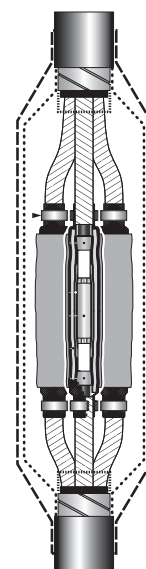

TT -24CSJ Transition Joint

Installation

In-service experience has shown that the reliability of underground networks is dependent on the careful transportation, drum handling and quality of the cable installation on the site.

CABLE DRUM HANDLING

Cable drums should be handled with care using correct mechanical handling equipment for the lifting and movement of drums on site.

Drums should be stored on firm flat ground on the edge of the flanges, never laid flat on the ground.

Rolling of drums

To prevent cable “crawl” drums must be rolled in the direction indicated by the arrows on both flanges. Care must be taken when drums are rolled against each other, especially when cardboard protection is used, or if ordinary plank protection has been removed.

Lifting

When using wires or ropes for lifting, these have to be parallel to the flanges to prevent inward pressure (use spreader).

Lifting

When using a fork lift truck, the forks must be applied across the flanges and have sufficient reach. Drums must be lowered gently, not dropped.

INSTALLATION ENVIRONMENT

The cable designs described in this publication are suitable for use on indoor and outdoor installations. Where cables are to be laid in damp conditions, consideration should be given to water-blocked designs. For cables installed in very wet situations, either partially or fully submerged, then special designs for submersible applications should be used.

Prior to installation, a detailed route survey should be carried out to plan where cables will be jointed and to identify any possible obstructions which may require special civil engineering works such as directional drilling.

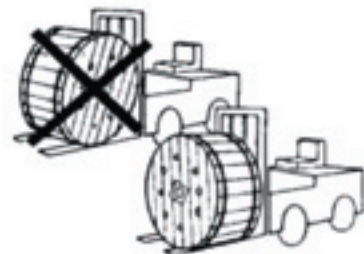
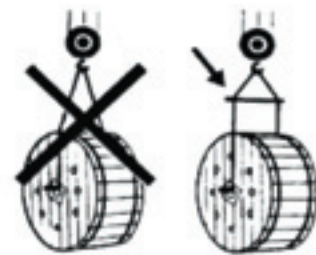
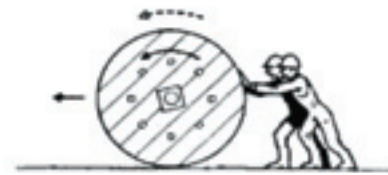

Cable pulling should be planned to ensure a smooth easy passage. Rollers to prevent any dragging of the sheath on the floor and at changes in direction should be used.

Care should be used to prevent any damage to the outer sheath, as any ingress of moisture can cause problems in the cable.



Installation

TYPE OF INSTALLATION

Medium voltage cables can be laid directly in the ground, or pulled into ducts laid in the ground, or run in tunnels or above ground on cable trays/ladders.

Cables can be laid in trefoil (three cores arranged in a triangular formation), or flat, dependant upon the actual requirements for each arrangement.

Cables directly buried in flat formation

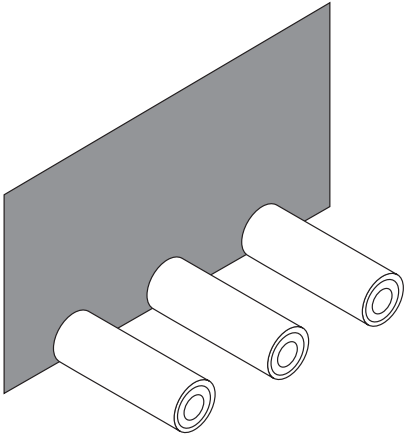

Cables buried directly in trefoil formation

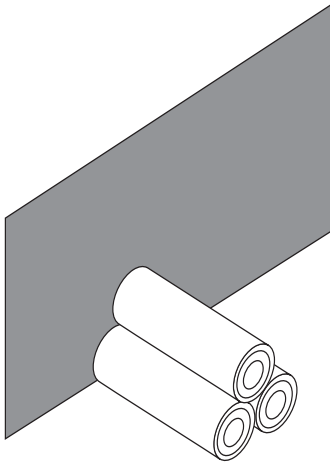

Cables in the air inside a gallery in touching trefoil formation

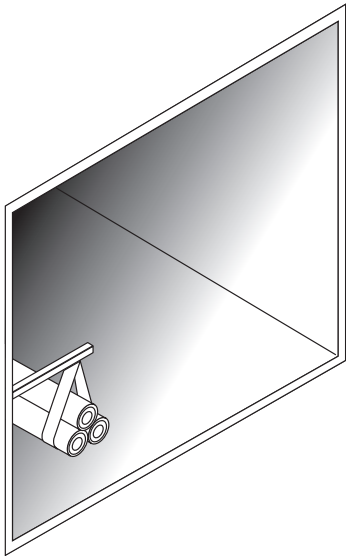

Cables buried in plastic ducts in tight trefoil formation

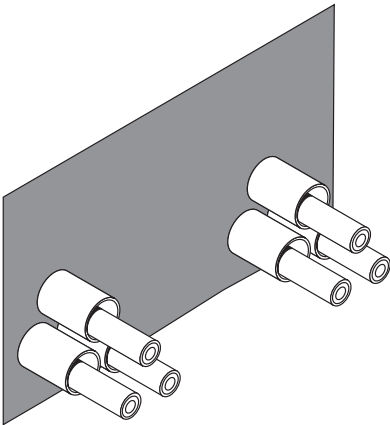

Installation

Where multiple single core circuits are laid, care must be taken to ensure how the phases are connected to ensure a balanced current distribution is achieved.

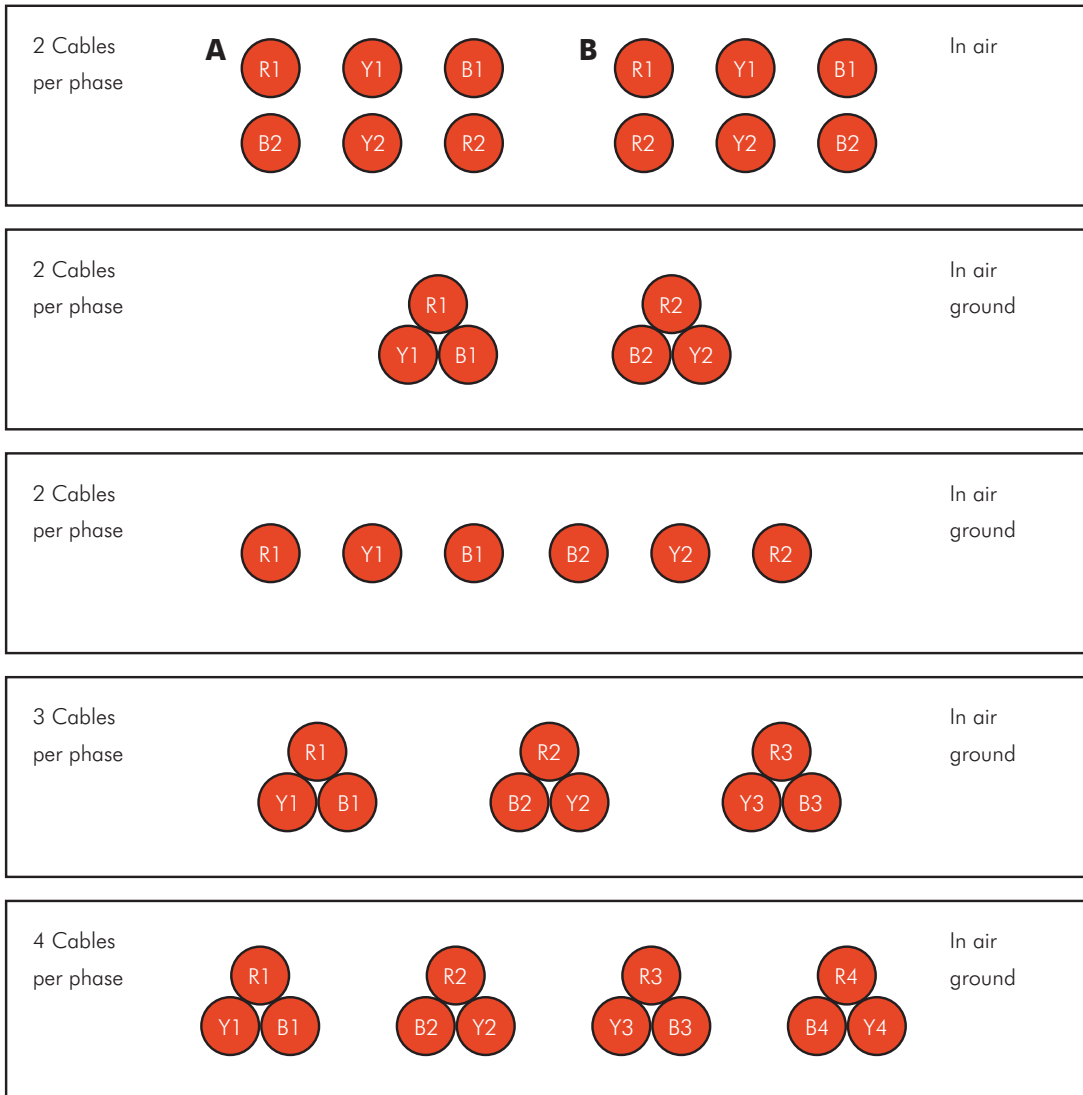

INSTALLATION TEMPERATURE

To avoid the risk of damage during installation, cables should only be pulled when the temperature is above 0°C, and have stood for over 24 hours above this temperature to ensure the cables are fully acclimatised.

Cables with HFFR sheaths have better performances at low temperature and can be safely installed at temperatures down to -10°C.

Cables with PVC sheaths should be installed at temperatures below 35°C to prevent any possible sheath damage.



Installation

MAXIMUM PERMISSIBLE TENSILE FORCE DURING PULLING

The tensile force applied during the pulling of the cables into position must be compatible with the mechanical strength of the cables. It is advisable to use a dynamometer to continuously check the pulling tension to ensure the forces do not exceed the recommended guidelines as follows:

- 50N /mm² for cables with copper conductors
- 30N /mm² for cables with aluminium conductors

In the case of three core cables, the cross sectional area of all three cores is taken into account.

For example, 3 x 120mm² Copper cable = (3x120x50) = 18,000N (1800kg)

When pulling cable using a cable grip on the sheath, the maximum permissible tensile force is same as that on the conductor as calculated above. However, following installation it is recommended to cut off two metres beyond the point where the cable grip is attached and check for no signs of stretching on the sheath.

MINIMUM BENDING RADIUS DURING INSTALLATION

Cables should not be bent to a radius smaller than the recommended values (table, top right).

Type of screen and cores	Minimum bending radius during installation (expressed as multiple of the cable overall diameter D)	Minimum bending radius after installation (cables fixed to a former)
Copper wire screen, single core	20 x D	15 x D
Copper wire screen, three core	16 x D	12 x D
Armoured, single core	16 x D	12 x D
Armoured, three core	14 x D	10 x D
Lead sheathed, un-armoured single core	24 x D	20 x D
Lead sheathed, armoured three core	16 x D	12 x D
Aluminium foil laminate, single core	24 x D	20 x D
Aluminium foil laminate, three core	12 x D	10 x D

CABLE SUPPORT SPACING

Cable systems need to be adequately fixed to a surface to prevent problems with expansion and contraction during service, and to contain the cables in the event of a short-circuit which creates high electro-dynamic loads between the phases, which would create uncontrollable damage to the cable and surrounding area without the necessary fixings.

It is important to design a cable support system which provides the necessary clamping force to withstand the forces generated in service and short-circuit conditions.

The table below gives some preliminary indications of the necessary spacings for cables system, however, any final design should be made for each specific installation taking all factors into consideration.

Aluminium conductors	Support spacing	
	Diameter of cable	
	Horizontal (mm)	Vertical (mm)
15-20	1200	550
20-40	2000	600
40-60	3000	900
>60	4000	1300
Copper conductors	Horizontal (mm)	Vertical (mm)
15-20	400	550
20-40	450	600
40-60	700	900
>60	1100	1300

Installation

SPECIAL CIVIL ENGINEERING WORKS

For crossing obstacles such as rivers, roads or railway crossings, it may be necessary to employ special techniques to bore holes to accommodate cables or ducts.

Horizontal Directional Drilling (HDD) is one such technique which is particularly useful for crossing waterways.

The diagrams below gives an example of the horizontal directional drilling process, showing some of the equipment used.

Pilot hole



Tubing

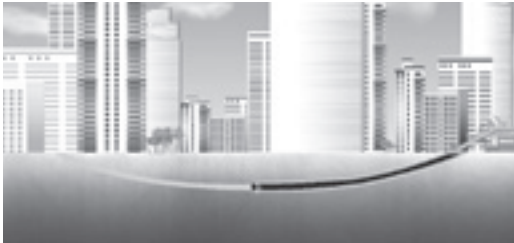

Boring



Pulling



TESTS AFTER INSTALLATION

Following installation of the cable sections or complete circuits (cables and accessories), tests to check the integrity of the sheath and the insulation should be made.

The exact type and duration of the tests should be agreed between the purchaser and installation contractor but typical commission tests would consist of:

D.C. sheath integrity test

After installation, all the sheaths shall be tested during 1 minute at a voltage level according to the thickness of the sheath of the cable as follows:

Extruded PVC or polyethylene: 4kV DC per mm of thickness with a maximum of 10kV D.C.

The minimum average thickness shall be used to calculate the voltage test.

A.C insulation tests

An A.C. voltage test at power frequency, in accordance with item a) or b) below, may be used:

a) Test for 5 min with the phase-to-phase voltage of the system applied between the conductor and the metallic screen/sheath;

b) Test for 24 h with the normal operating voltage of the system.

Current ratings for copper and aluminium conductors

The figures given in the following tables allow an initial estimation to be made of the required cable cross section area and type.

However, they cannot replace a full calculation made by Nexans Technical experts which will take into account specific conditions for individual installations.

CONDUCTOR CROSS SECTION AND CALCULATION OF THE CONTINUOUS CURRENT RATING

The conductor cross section is determined by the current carry capacity of each phase according to the following formula:

$$I = \frac{S}{\sqrt{3} \times U} \text{ in amperes}$$

where:

I = current rating

S = apparent power of the line in kVA

U = the rated phase to phase voltage

The conductor cross section must be of sufficient size so that the heating of the cable insulation due to the resistance and dielectric losses generated in the cable is compatible to its resistance to heat.

The maximum rated temperatures are as follows for XLPE insulated cables

Temperature under rated operating conditions	90°C
Temperature under emergency operating conditions	105°C
Temperature in the event of a short-circuit (< 5 sec)	250°C

If the cables are buried in the ground and loaded continuously, consideration should be given to the possibility of a local increase in soil thermal resistivity due to moisture migration, making it desirable to reduce the maximum conductor operating temperature to 80°C.

The current ratings in the following tables are given for three standard methods of installation; laid direct, in single way ducts or in air. They need to be adjusted according to the actual parameters for each installation:

- the arrangement of the cables (trefoil or flat formation).
- the depth of laying.
- the thermal resistivity of the ground (expressed in K m/W).
- the temperature of the surrounding ground.
- the temperature of the ambient air.
- the proximity effect from adjacent circuits.
- the screen bonding arrangement (i.e. single point or solid bonding).
- the material and diameters of ducts.

The correction factors in the tables below can be used to determine the effect on the current ratings:

Laying depth in metres	0.5	0.6	0.8	1.0	1.5	2.0	3.0
Correction Factor	1.05	1.02	1.0	0.97	0.93	0.89	0.86

Thermal resistivity of the ground K. m/W	0.8	1.0	1.2	1.5	2.0	2.5
Correction Factor	1.07	1.02	1.0	0.93	0.89	0.86

Ground temperature in °C	10	15	20	25	30	35	40
Correction Factor	1.03	1.0	0.97	0.93	0.89	0.86	0.82

Air temperature in °C	25	30	35	40	50	55
Correction Factor	1.0	0.95	0.92	0.88	0.78	0.73

Proximity effects distance between 2 circuits (mm)	0.15	0.30	0.45	0.60
1 circuit	1.00	1.00	1.00	1.00
2 circuits	0.85	0.89	0.90	0.92
3 circuits	0.75	0.80	0.84	0.86
4 circuits	0.70	0.77	0.80	0.84

Technical Specifications

• 3.8/6.6 (7.2) kv Three Core armoured copper conductors	27
• 6.35/11 (12) kv Triplex / Single Core unarmoured copper conductors	28
• 6.35/11 (12) kv Triplex / Single Core unarmoured aluminium conductors	29
• 6.35/11 (12) kv Three Core unarmoured copper conductors	30
• 6.35/11 (12) k Three Core unarmoured aluminium conductors	31
• 6.35/11 (12) kv Single Core armoured copper conductors	32
• 6.35/11 (12) kv Single Core armoured aluminium conductors	33
• 6.35/11 (12) kv Three Core armoured copper conductors	34
• 6.35/11 (12) kv Three Core armoured aluminium conductors	35
• 8.7/15 (17.5) kv Single Core armoured copper conductors	36
• 8.7/15 (17.5) kv Three Core armoured copper conductors	37
• 12/20 (22) kv Single Core copper unarmoured conductors	38
• 12/20 (22) kv Single Core armoured copper conductors	39
• 12/20 (22) kv Three Core armoured copper conductors	40
• 19/33 (36) kv Single Core unarmoured copper conductors	41
• 19/33 (36) kv Single Core unarmoured aluminium conductors	42
• 19/33 (36) kv Single Core armoured copper conductors	43
• 19/33 (36) kv Three Core armoured copper conductors	44

Voltage 3.8/6.6 (7.2) kv Three Core armoured copper conductors

Typical technical data

Design Standards:
BS 6622 / BS7835

Nominal cross-sectional area	mm ²	3x25	3x35	3x50	3x70	3x95	3x120	3x150	3x185	3x240	3x300	3x400
Diameter over conductor	mm	6.00	7.00	8.10	9.80	11.50	12.80	14.30	15.90	18.40	20.50	23.20
Approximate diameter over insulation	mm	12.1	13.2	14.3	16	17.7	19	20.5	22.1	24.8	27.7	31.2
Approximate overall diameter	mm	45	48	52	56	60	64	67	70	76	85	93
Approximate weight of cable	kg/m	3600	4100	5200	6150	7300	8450	9550	11000	13350	16950	20450
Minimum bending radius (static)	mm	550	600	650	700	750	800	850	850	950	1050	1150
Maximum pulling tension on cable	kg	375	525	750	1050	1425	1800	2250	2775	3600	4500	5000
Maximum DC resistance @20°C	Ω/km	0.727	0.524	0.387	0.268	0.193	0.153	0.124	0.0991	0.0754	0.0601	0.047
Maximum AC resistance@ 90°C	Ω/km	0.927	0.668	0.494	0.342	0.247	0.196	0.16	0.128	0.0986	0.0798	0.064
Inductance	mH/km	0.397	0.376	0.35	0.331	0.316	0.303	0.294	0.288	0.297	0.272	0.267
Reactance@50Hz	Ω/km	0.125	0.118	0.11	0.104	0.099	0.095	0.093	0.091	0.088	0.085	0.084
Impedance @ 50Hz @ 90°C	Ω/km	0.936	0.679	0.506	0.358	0.266	0.218	0.184	0.157	0.132	0.117	0.105
Maximum capacitance (C)	μF/km	0.261	0.293	0.325	0.371	0.419	0.458	0.497	0.531	0.575	0.605	0.631
Maximum charging current	A/km	0.31	0.35	0.39	0.44	0.5	0.55	0.59	0.64	0.69	0.72	0.76
Short circuit ratings												
1 second short-circuit rating of conductor (90 to 250°C)	26/08/2009	3.5	4.9	6.7	9.7	13.5	17.1	21	26.3	34.6	43.4	55.6
1 second short-circuit rating of metallic screen (80 to 250°C)	kA	3.5	4.9	6.7	9.7	12.5	13.4	14.1	15	16.4	23.2	25.4
Continuous current carrying capacity (as per conditions detailed below)												
Direct buried	Amps	140	170	210	255	300	340	380	430	490	540	590
Single way ducts	Amps	125	150	180	215	255	290	330	370	425	470	520
In air	Amps	145	175	220	270	330	375	430	490	570	650	700

The following conditions have been assumed to calculate the current ratings:

Directly buried in ground

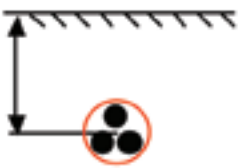

Laid in single way ducts

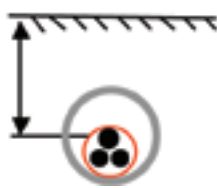

In air



- Thermal resistivity of soil = 1.2 K.m/W
- Ground temperature = 15°C
- Ambient air temperature = 25°C
- Depth of burial (to centre of cable, duct or trefoil group) = 800mm

Voltage 6.35/11 (12) kv Triplex / Single Core unarmoured copper conductors

Typical technical data

Design Standards:
BS 7870-4.10
IEC 60502

Nominal cross-sectional area	mm ²	70	95	120	150	185	240	300	400	500	630	800	1000
Diameter over conductor	mm	9.8	11.5	12.8	14.3	15.9	18.4	20.5	23.2	26.2	30.3	34.7	38
Approximate diameter over insulation	mm	27	28.7	30	31.5	33.1	35.6	38.1	41.2	44.2	48.3	52.7	57.3
Approximate overall diameter	mm	34.1	36.1	37.5	39.3	41	43.8	46.6	50.2	53.4	58	66	71
Approximate weight of cable	kg/m	1560	1880	2160	2480	2860	3530	4220	5150	6250	7740	9630	12200
Approximate overall diameter of triplex group	mm	51	58	60	65	70	75	88	94	-	-	-	-
Approximate weight of triplex group	kg/m	4680	5640	6480	7440	8580	10590	12660	15450	-	-	-	-
Minimum bending radius (static)	mm	340	360	380	390	420	440	470	500	540	580	660	710
Maximum pulling tension on cable	kg	350	475	600	750	925	1200	1500	2000	2500	3150	4000	5000
Maximum DC resistance @20°C	Ω/km	0.268	0.193	0.153	0.124	0.0991	0.0754	0.0601	0.047	0.0366	0.0283	0.0221	0.0176
Maximum AC resistance@ 90°C	Ω/km	0.342	0.247	0.196	0.159	0.128	0.098	0.079	0.063	0.051	0.042	0.035	0.03
Inductance	mH/km	0.396	0.378	0.361	0.351	0.343	0.328	0.316	0.305	0.297	0.288	0.275	0.268
Reactance@50Hz	Ω/km	0.124	0.119	0.114	0.11	0.108	0.103	0.099	0.096	0.093	0.09	0.086	0.084
Impedance @ 50Hz @ 90°C	Ω/km	0.364	0.274	0.226	0.194	0.167	0.142	0.127	0.115	0.106	0.099	0.093	0.089
Maximum capacitance (C)	μF/km	0.289	0.324	0.353	0.382	0.407	0.455	0.51	0.565	0.623	0.693	0.815	0.904
Maximum charging current	A/km	0.58	0.65	0.71	0.76	0.81	0.91	1.02	1.13	1.24	1.38	1.63	1.8
Short circuit ratings													
1 second short-circuit rating of conductor (90 to 250°C)	kA	9.7	13.5	17.1	21	26.3	34.6	43.4	57.7	72.1	90.7	115.1	143.8
1 second short-circuit rating of a 35mm ² Copper wire screen (80 to 250°C)	kA	4.8	4.8	4.8	4.8	4.8	4.8	4.8	4.8	4.8	4.8	4.8	4.8
1 second short-circuit rating of a 50mm ² Copper wire screen (80 to 250°C)	kA	8.2	8.2	8.2	8.2	8.2	8.2	8.2	8.2	8.2	8.2	8.2	8.2
Continuous Current Carrying Capacity (as per conditions detailed below)													
Direct buried	Amps	270	320	360	410	460	530	600	690	760	850	930	1010
Single way ducts	Amps	270	320	360	405	445	520	570	630	700	780	860	920
In air	Amps	320	390	445	510	580	680	770	890	1020	1160	1290	1430

The following conditions have been assumed to calculate the current ratings:

Directly buried in ground

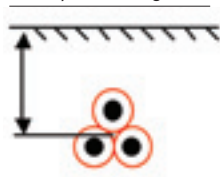

Laid in single way ducts

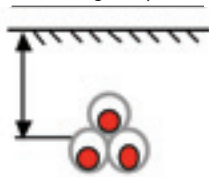

In air

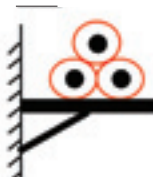

- Cables laid in tight trefoil
- Thermal resistivity of soil = 1.2 K.m/W
- Ground temperature = 15°C
- Ambient air temperature = 25°C
- Depth of burial (to centre of cable, duct or trefoil group) = 800mm

Voltage 6.35/11 (12) kv Triplex / Single Core unarmoured aluminium conductors

Typical technical data

Design Standards:
BS 7870-4.10
IEC 60502

Nominal cross-sectional area	mm ²	70	95	120	150	185	240	300	400	500	630	800	1000
Diameter over conductor	mm	9.8	11.5	12.8	14.3	15.9	18.4	20.5	23.2	26.2	30.3	34.7	38
Approximate diameter over insulation	mm	27	28.7	30	31.5	33.1	35.6	38.1	41.2	44.2	48.3	52.7	57.3
Approximate overall diameter	mm	34.1	36.1	37.5	39.3	41	43.8	46.6	50.2	53.4	58	66	71
Approximate weight of cable	kg/m	1050	1150	1300	1400	1550	1800	2050	2400	2800	3300	4050	4800
Approximate overall diameter of triplex group	mm	51	58	60	65	70	75	88	94	-	-	-	-
Approximate weight of triplex group	kg/m	3150	3450	3900	4200	4650	5400	6150	7200	-	-	-	-
Minimum bending radius (static)	mm	340	360	380	390	420	440	470	500	540	580	660	710
Maximum pulling tension on cable	kg	210	475	600	750	925	1200	1500	2000	2500	3150	4000	5000
Maximum DC resistance @20°C	Ω/km	0.443	0.320	0.253	0.206	0.164	0.125	0.100	0.078	0.061	0.047	0.037	0.029
Maximum AC resistance@ 90°C	Ω/km	0.568	0.411	0.325	0.265	0.211	0.161	0.130	0.102	0.080	0.063	0.051	0.042
Inductance	mH/km	0.422	0.401	0.385	0.377	0.364	0.348	0.336	0.325	0.320	0.310	0.295	0.287
Reactance@50Hz	Ω/km	0.133	0.126	0.121	0.119	0.114	0.109	0.106	0.102	0.100	0.097	0.093	0.090
Impedance @ 50Hz @ 90°C	Ω/km	0.583	0.429	0.347	0.29	0.24	0.195	0.167	0.144	0.128	0.116	0.106	0.1
Maximum capacitance (C)	μF/km	0.289	0.324	0.353	0.382	0.417	0.465	0.51	0.565	0.623	0.693	0.815	0.904
Maximum charging current	A/km	0.58	0.65	0.71	0.76	0.83	0.93	1.02	1.13	1.24	1.38	1.63	1.8
Short circuit ratings													
1 second short-circuit rating of conductor (90 to 250°C)	kA	6.4	8.9	11.3	13.9	17.4	22.9	28.7	36.8	46.4	59.9	>60	>60
1 second short-circuit rating of a 35mm ² Copper wire screen (80 to 250°C)	kA	4.8	4.8	4.8	4.8	4.8	4.8	4.8	4.8	4.8	4.8	4.8	4.8
1 second short-circuit rating of a 50mm ² Copper wire screen (80 to 250°C)	kA	8.2	8.2	8.2	8.2	8.2	8.2	8.2	8.2	8.2	8.2	8.2	8.2
Continuous current carrying capacity (as per conditions detailed below)													
Direct buried	Amps	210	250	280	320	360	415	475	540	610	680	770	850
Single way ducts	Amps	215	255	285	315	350	405	455	510	570	640	710	790
In air	Amps	240	300	335	380	435	510	600	700	810	930	1070	1210

The following conditions have been assumed to calculate the current ratings:

Directly buried in ground

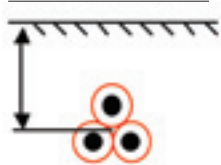

Laid in single way ducts

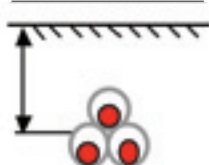

In air

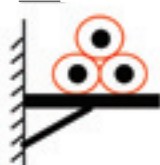

- Cables laid in tight trefoil
- Thermal resistivity of soil = 1.2 K.m/W
- Ground temperature = 15°C
- Ambient air temperature = 25°C
- Depth of burial (to centre of cable, duct or trefoil group) = 800mm

Voltage 6.35/11 (12) kv Three Core unarmoured copper conductors

Typical technical data

Design Standards:
BS 7870-4.20
IEC 60502

Nominal cross-sectional area	mm ²	3x70	3x95	3x120	3x150	3x185	3x240	3x300	3x400
Diameter over conductor	mm	9.8	11.5	12.8	14.3	15.9	18.4	20.5	23.2
Approximate diameter over insulation	mm	27	28.7	30	31.5	33.1	35.6	38.1	41.2
Approximate overall diameter	mm	55	60	63	67	69	75	81	88
Approximate weight of cable	kg/m	4300	5300	6250	7250	8500	10500	12700	15550
Minimum bending radius (static)	mm	850	900	950	1000	1050	1150	1250	1350
Maximum pulling tension on cable	kg	1050	1425	1800	2250	2775	3600	4500	5000
Maximum DC resistance @20°C	Ω/km	0.268	0.193	0.153	0.124	0.0991	0.0754	0.0601	0.047
Maximum AC resistance@ 90°C	Ω/km	0.342	0.247	0.196	0.159	0.128	0.098	0.079	0.063
Inductance	mH/km	0.396	0.378	0.361	0.351	0.343	0.328	0.316	0.305
Reactance@50Hz	Ω/km	0.124	0.119	0.114	0.11	0.108	0.103	0.099	0.096
Impedance @ 50Hz @ 90°C	Ω/km	0.364	0.274	0.226	0.194	0.167	0.142	0.127	0.115
Maximum capacitance (C)	μF/km	0.289	0.324	0.353	0.382	0.407	0.455	0.51	0.565
Maximum charging current	A/km	0.58	0.65	0.71	0.76	0.81	0.91	1.02	1.13
Short circuit ratings									
1 second short circuit-rating of conductor (90 to 250°C)	kA	9.7	13.5	17.1	21	26.3	34.6	43.4	57.7
1 second short circuit-rating of a 35mm ² Copper wire screen (80 to 250°C)	kA	4.8	4.8	4.8	4.8	4.8	4.8	4.8	4.8
1 second short circuit-rating of a 50mm ² Copper wire screen (80 to 250°C)	kA	8.2	8.2	8.2	8.2	8.2	8.2	8.2	8.2
Continuous current carrying capacity (as per conditions detailed below)									
Direct buried	Amps	255	300	340	380	430	500	560	610
Single way ducts	Amps	220	255	295	325	370	430	485	530
In air	Amps	285	330	385	435	500	580	660	710

The following conditions have been assumed to calculate the current ratings:

Directly buried in ground

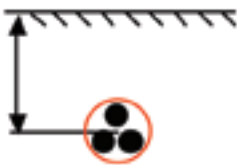

Laid in single way ducts

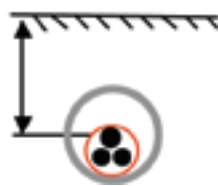

In air



- Thermal resistivity of soil = 1.2 K.m/W
- Ground temperature = 15°C
- Ambient air temperature = 25°C
- Depth of burial (to centre of cable, duct or trefoil group) = 800mm

Voltage 6.35/11 (12) kv Three Core unarmoured aluminium conductors

Typical technical data

Design Standards:
BS 7870-4.20
IEC 60502

Nominal cross-sectional area	mm ²	3x70	3x95	3x120	3x150	3x185	3x240	3x300	3x400
Diameter over conductor	mm	9.8	11.5	12.8	14.3	15.9	18.4	20.5	23.2
Approximate diameter over insulation	mm	27	28.7	30	31.5	33.1	35.6	38.1	41.2
Approximate overall diameter	mm	55	60	63	67	69	75	81	88
Approximate weight of cable	kg/m	3000	3500	3950	4400	5000	5950	6900	8100
Minimum bending radius (static)	mm	850	900	950	1000	1050	1150	1250	1350
Maximum pulling tension on cable	kg	630	855	1080	1350	1665	2160	2700	3600
Maximum DC resistance @20°C	Ω/km	0.4430	0.3200	0.2530	0.2060	0.1640	0.1250	0.1000	0.0778
Maximum AC resistance@ 90°C	Ω/km	0.5680	0.4110	0.3250	0.2650	0.2110	0.1610	0.1300	0.1020
Inductance	mH/km	0.422	0.401	0.385	0.377	0.364	0.348	0.336	0.325
Reactance@50Hz	Ω/km	0.133	0.126	0.121	0.119	0.114	0.109	0.106	0.102
Impedance @ 50Hz @ 90°C	Ω/km	0.583	0.429	0.347	0.29	0.24	0.195	0.167	0.144
Maximum capacitance (C)	μF/km	0.289	0.324	0.353	0.382	0.417	0.465	0.51	0.565
Maximum charging current	A/km	0.58	0.65	0.71	0.76	0.83	0.93	1.02	1.13
Short circuit ratings									
1 second short circuit-rating of conductor (90 to 250°C)	kA	6.4	8.9	11.3	13.9	17.4	22.9	28.7	36.8
1 second short circuit-rating of a 35mm ² Copper wire screen (80 to 250°C)	kA	4.8	4.8	4.8	4.8	4.8	4.8	4.8	4.8
1 second short circuit-rating of a 50mm ² Copper wire screen (80 to 250°C)	kA	8.2	8.2	8.2	8.2	8.2	8.2	8.2	8.2
Continuous current carrying capacity (as per conditions detailed below)									
Direct buried	Amps	200	235	265	295	335	390	435	500
Single way ducts	Amps	170	200	230	255	290	340	380	435
In air	Amps	220	255	295	335	385	450	510	595

The following conditions have been assumed to calculate the current ratings:

Directly buried in ground

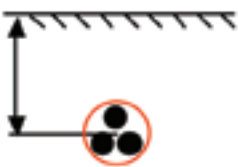

Laid in single way ducts

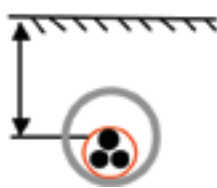

In air



- Thermal resistivity of soil = 1.2 K.m/W
- Ground temperature = 15°C
- Ambient air temperature = 25°C
- Depth of burial (to centre of cable, duct or trefoil group) = 800mm

Voltage 6.35/11 (12) kv Single Core armoured copper conductors

Typical technical data

Design Standards:
BS 6622
BS 7835

Nominal cross-sectional area	mm ²	70	95	120	150	185	240	300	400	500	630	800	1000
Diameter over conductor	mm	9.8	11.5	12.8	14.3	15.9	18.4	20.5	23.2	26.2	30.3	34.7	38
Approximate diameter over insulation	mm	17.8	19.4	20.9	22.2	24.2	26	28.9	32.1	35	39.1	43.7	32.3
Approximate overall diameter	mm	32	34	36	38	40	43	45	48	53	56	63	68
Approximate weight of cable	kg/m	1650	1950	2250	2700	3100	3750	4450	5400	6700	8200	10200	12450
Minimum bending radius (static)	mm	650	700	750	800	800	850	900	1000	1050	1150	1250	1400
Maximum pulling tension on cable	kg	350	475	600	750	925	1200	1500	2000	2500	3150	4000	5000
Maximum DC resistance @20°C	Ω/km	0.2680	0.1930	0.1530	0.1240	0.0991	0.0754	0.0601	0.0470	0.0366	0.0283	0.0221	0.0176
Maximum AC resistance @ 90°C	Ω/km	0.3420	0.2470	0.1960	0.1590	0.1280	0.0977	0.0787	0.0627	0.0502	0.0407	0.0340	0.0293
Inductance	mH/km	0.422	0.401	0.385	0.377	0.368	0.351	0.336	0.325	0.320	0.310	0.295	0.287
Reactance @50Hz	Ω/km	0.133	0.126	0.121	0.119	0.115	0.110	0.106	0.102	0.100	0.097	0.093	0.090
Impedance @ 50Hz @ 90°C	Ω/km	0.367	0.277	0.23	0.198	0.172	0.147	0.132	0.12	0.112	0.106	0.099	0.0904
Maximum capacitance (C)	μF/km	0.289	0.324	0.353	0.382	0.407	0.455	0.51	0.565	0.623	0.693	0.815	0.904
Maximum charging current	A/km	0.58	0.65	0.71	0.76	0.81	0.91	1.02	1.13	1.24	1.38	1.63	1.8
Short circuit ratings													
1 second short circuit-rating of conductor (90 to 250°C)	kA	9.7	13.5	17.1	21	26.3	34.6	43.4	55.6	>60	>60	>60	>60
1 second short circuit-rating of metallic screen (80 to 200°C)	kA	7.6	8.2	8.7	10.9	11.4	12.2	13.3	14.4	19.6	21.2	24.2	26.2
Continuous current carrying capacity (as per conditions detailed below)													
Direct buried	Amps	270	320	360	410	455	520	580	650	710	760	810	860
Single way ducts	Amps	360	305	340	375	410	460	500	530	570	620	670	700
In air	Amps	310	375	430	490	550	650	740	840	930	1040	1160	1250

The following conditions have been assumed to calculate the current ratings:

Directly buried in ground

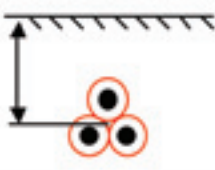

Laid in single way ducts

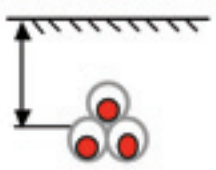

In air



- Cables laid in tight trefoil
- Thermal resistivity of soil = 1.2 K.m/W
- Ground temperature = 15°C
- Ambient air temperature = 25°C
- Depth of burial (to centre of cable, duct or trefoil group) = 800mm

Voltage 6.35/11 (12) kv Single Core armoured aluminium conductors

Typical technical data

Design Standards:
BS 6622
BS 7835

Nominal cross-sectional area	mm ²	70	95	120	150	185	240	300	400	500	630	800	1000
Diameter over conductor	mm	9.8	11.5	12.8	14.3	15.9	18.4	20.5	23.2	26.2	30	34.7	38
Approximate diameter over insulation	mm	17.8	19.4	20.9	22.2	24.2	26	28.9	32.1	35	39.1	43.7	47.1
Approximate overall diameter	mm	32	34	36	38	40	43	45	48	53	56	63	68
Approximate weight of cable	kg/m	1200	1350	1500	1750	1950	2250	2550	2950	3600	4200	5100	6000
Minimum bending radius (static)	mm	650	700	750	800	800	850	900	1000	1050	1150	1250	1400
Maximum pulling tension on cable	kg	210	285	360	450	555	720	900	1200	1500	1890	2400	3000
Maximum DC resistance @20°C	Ω/km	0.443	0.320	0.253	0.206	0.164	0.125	0.100	0.078	0.061	0.047	0.037	0.029
Maximum AC resistance@ 90°C	Ω/km	0.568	0.411	0.325	0.265	0.211	0.161	0.130	0.102	0.080	0.063	0.051	0.042
Inductance	mH/km	0.422	0.401	0.385	0.377	0.364	0.348	0.336	0.325	0.320	0.310	0.295	0.287
Reactance@50Hz	Ω/km	0.133	0.126	0.121	0.119	0.114	0.109	0.106	0.102	0.100	0.097	0.093	0.090
Impedance @ 50Hz @ 90°C	Ω/km	0.583	0.429	0.347	0.29	0.24	0.195	0.167	0.144	0.128	0.116	0.106	0.1
Maximum capacitance (C)	μF/km	0.289	0.324	0.353	0.382	0.417	0.465	0.51	0.565	0.623	0.693	0.815	0.904
Maximum charging current	A/km	0.58	0.65	0.71	0.76	0.83	0.93	1.02	1.13	1.24	1.38	1.63	1.8
Short circuit ratings													
1 second short circuit-rating of conductor (90 to 250°C)	kA	6.4	8.9	11.3	13.9	17.4	22.9	28.7	36.8	46.4	59.9	>60	>60
1 second short circuit-rating of metallic screen (80 to 200°C)	kA	6.4	8.2	8.7	10.9	11.7	12.5	13.3	14.4	19.6	21.2	24.2	26.2
Continuous current carrying capacity (as per conditions detailed below)													
Direct buried	Amps	210	250	280	315	355	405	455	510	570	640	700	760
Single way ducts	Amps	210	245	275	300	335	380	420	455	500	550	600	640
In air	Amps	240	295	335	380	435	510	580	670	770	880	1000	1100

The following conditions have been assumed to calculate the current ratings:

Directly buried in ground

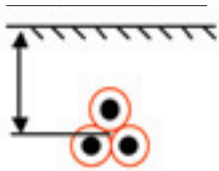

Laid in single way ducts

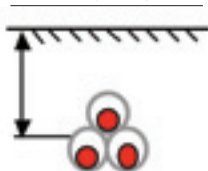

In air

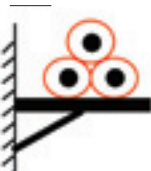

- Cables laid in tight trefoil
- Thermal resistivity of soil = 1.2 K.m/W
- Ground temperature = 15°C
- Ambient air temperature = 25°C
- Depth of burial (to centre of cable, duct or trefoil group) = 800mm

Voltage 6.35/11 (12) kv Three Core armoured copper conductors

Typical technical data

Design Standards:
BS 6622
BS 7835

Nominal cross-sectional area	mm ²	3x70	3x95	3x120	3x150	3x185	3x240	3x300	3x400
Diameter over conductor	mm	9.8	11.5	12.8	14.3	15.9	18.4	20.5	23.2
Approximate diameter over insulation	mm	17.8	19.5	20.8	22.3	23.9	26.4	28.9	32.0
Approximate overall diameter	mm	60	65	68	72	75	82	89	95
Approximate weight of cable	kg/m	6750	8000	9100	10250	11650	14900	17450	20850
Minimum bending radius (static)	mm	750	800	850	900	900	1000	1100	1150
Maximum pulling tension on cable	kg	1050	1425	1800	2250	2775	3600	4500	5000
Maximum DC resistance @20°C	Ω/km	0.2680	0.1930	0.1530	0.1240	0.0991	0.0754	0.0601	0.0470
Maximum AC resistance@ 90°C	Ω/km	0.3420	0.2470	0.1960	0.1600	0.1280	0.0986	0.0798	0.0640
Inductance	mH/km	0.350	0.333	0.320	0.310	0.303	0.290	0.280	0.271
Reactance@50Hz	Ω/km	0.110	0.105	0.100	0.097	0.095	0.091	0.088	0.085
Impedance @ 50Hz @ 90°C	Ω/km	0.359	0.268	0.220	0.187	0.160	0.134	0.119	0.107
Maximum capacitance (C)	μF/km	0.289	0.324	0.353	0.382	0.407	0.455	0.510	0.565
Maximum charging current	A/km	0.58	0.65	0.71	0.76	0.81	0.91	1.02	1.13
Short circuit ratings									
1 second short circuit-rating of conductor (90 to 250°C)	kA	9.7	13.5	17.1	21	26.3	34.6	43.4	55.6
1 second short circuit-rating of metallic screen (80 to 250°C)	kA	9.7	13.5	14.6	15.3	16	22.1	23.9	26.1
Continuous current carrying capacity (as per conditions detailed below)									
Direct buried	Amps	255	300	340	380	430	490	540	590
Single way ducts	Amps	215	255	290	330	370	425	470	520
In air	Amps	270	330	375	430	490	570	650	700

The following conditions have been assumed to calculate the current ratings:

Directly buried in ground

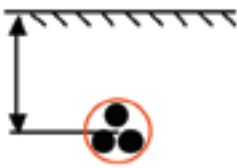

Laid in single way ducts

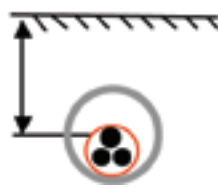

In air



- Thermal resistivity of soil = 1.2 K.m/W
- Ground temperature = 15°C
- Ambient air temperature = 25°C
- Depth of burial (to centre of cable, duct or trefoil group) = 800mm

Voltage 6.35/11 (12) kv Three Core armoured aluminium conductors

Typical technical data

Design Standards:
BS 6622
BS 7835

Nominal cross-sectional area	mm ²	3x70	3x95	3x120	3x150	3x185	3x240	3x300	3x400
Diameter over conductor	mm	9.8	11.5	12.8	14.3	15.9	18.4	20.5	23.2
Approximate diameter over insulation	mm	17.8	19.5	20.8	22.3	23.9	26.4	28.9	32.0
Approximate overall diameter	mm	60	65	68	72	75	82	89	95
Approximate weight of cable	kg/m	5400	6150	6800	7400	8250	10400	11650	13400
Minimum bending radius (static)	mm	750	800	850	900	900	1000	1100	1150
Maximum pulling tension on cable	kg	630	855	1080	1350	1665	2160	2700	3600
Maximum DC resistance @20°C	Ω/km	0.443	0.320	0.253	0.206	0.164	0.125	0.100	0.078
Maximum AC resistance@ 90°C	Ω/km	0.568	0.411	0.325	0.265	0.211	0.162	0.130	0.102
Inductance	mH/km	0.350	0.333	0.320	0.310	0.301	0.289	0.280	0.271
Reactance@50Hz	Ω/km	0.110	0.105	0.100	0.970	0.094	0.091	0.088	0.085
Impedance @ 50Hz @ 90°C	Ω/km	0.579	0.424	0.340	0.282	0.231	0.185	0.157	0.133
Maximum capacitance (C)	μF/km	0.289	0.324	0.353	0.382	0.417	0.465	0.510	0.565
Maximum charging current	A/km	0.58	0.65	0.71	0.76	0.83	0.93	1.02	1.13
Short circuit ratings									
1 second short circuit-rating of conductor (90 to 250°C)	kA	6.4	8.9	11.3	13.9	17.4	22.9	28.7	36.9
1 second short circuit-rating of metallic screen (80 to 250°C)	kA	6.4	8.9	11.3	13.9	16.2	22.5	23.9	26.1
Continuous current carrying capacity (as per conditions detailed below)									
Direct buried	Amps	195	230	265	300	335	380	435	490
Single way ducts	Amps	165	200	225	255	290	335	375	425
In air	Amps	210	250	295	330	385	450	510	590

The following conditions have been assumed to calculate the current ratings:

Directly buried in ground

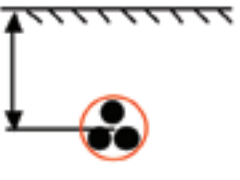

Laid in single way ducts

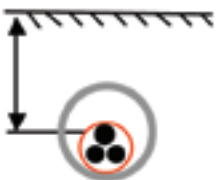

In air



- Thermal resistivity of soil = 1.2 K.m/W
- Ground temperature = 15°C
- Ambient air temperature = 25°C
- Depth of burial (to centre of cable, duct or trefoil group) = 800mm

Voltage 8.7/15 (17.5) kv Single Core armoured copper conductors

Typical technical data

Design Standards:
BS 6622
BS 7835

Nominal cross-sectional area	mm ²	70	95	120	150	185	240	300	400	500	630	800	1000
Diameter over conductor	mm	9.8	11.5	12.8	14.3	15.9	18.4	20.5	23.2	26.2	30.3	34.7	38
Approximate diameter over insulation	mm	20	21.7	23	24.5	26.1	28.6	31.1	34.2	37.2	41.3	45.7	49.4
Approximate overall diameter	mm	35	37	39	41	42	45	47	52	55	59	66	71
Approximate weight of cable	kg/m	1800	2200	2550	2850	3300	3950	4650	5800	6950	8500	10500	12800
Minimum bending radius (static)	mm	650	700	750	800	800	850	900	1000	1050	1150	1250	1400
Maximum pulling tension on cable	kg	350	475	600	750	925	1200	1500	2000	2500	3150	4000	5000
Maximum DC resistance @20°C	Ω/km	0.2680	0.1930	0.1530	0.1240	0.0991	0.0754	0.0601	0.0470	0.0366	0.0283	0.0221	0.0178
Maximum AC resistance @ 90°C	Ω/km	0.3420	0.2470	0.1960	0.1590	0.1270	0.0976	0.0786	0.0625	0.0500	0.0404	0.0338	0.0290
Inductance	mH/km	0.436	0.420	0.403	0.389	0.380	0.363	0.347	0.341	0.329	0.319	0.303	0.295
Reactance @ 50Hz	Ω/km	0.137	0.132	0.126	0.122	0.119	0.114	0.109	0.107	0.103	0.100	0.095	0.093
Impedance @ 50Hz @ 90°C	Ω/km	0.369	0.28	0.233	0.201	0.175	0.15	0.135	0.124	0.115	0.108	0.101	0.097
Maximum capacitance (C)	μF/km	0.232	0.259	0.282	0.303	0.323	0.359	0.401	0.442	0.486	0.539	0.632	0.699
Maximum charging current	A/km	0.63	0.71	0.77	0.83	0.88	0.98	1.09	1.2	1.32	1.47	1.72	1.9
Short circuit ratings													
1 second short circuit-rating of conductor (90 to 250°C)	kA	9.7	13.5	17.1	21	26.3	34.6	43.4	55.6	>60	>60	>60	>60
1 second short circuit-rating of metallic screen (80 to 200°C)	kA	8.3	10.9	11.4	11.7	12.2	13.3	14.1	19.1	20.8	22.5	25.4	27.5
Continuous current carrying capacity (as per conditions detailed below)													
Direct buried	Amps	270	320	360	410	455	520	580	650	710	760	810	860
Single way ducts	Amps	360	305	340	375	410	460	500	530	570	620	670	700
In air	Amps	310	375	430	490	550	650	740	840	930	1040	1160	1250

The following conditions have been assumed to calculate the current ratings:

Directly buried in ground

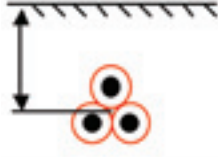

Laid in single way ducts

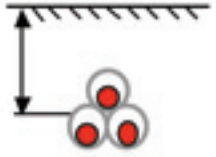

In air



- Cables laid in tight trefoil
- Thermal resistivity of soil = 1.2 K.m/W
- Ground temperature = 15°C
- Ambient air temperature = 25°C
- Depth of burial (to centre of cable, duct or trefoil group) = 800mm

Voltage 8.7/15 (17.5) kv Three Core armoured copper conductors

Typical technical data

Design Standards:
BS 6622
BS 7835

Nominal cross-sectional area	mm ²	3x70	3x95	3x120	3x150	3x185	3x240	3x300	3x400
Diameter over conductor	mm	9.8	11.5	12.8	14.3	15.9	18.4	20.5	23.2
Approximate diameter over insulation	mm	20	21.7	23	24.5	26.1	28.6	31.1	34.2
Approximate overall diameter	mm	66	70	74	77	82	88	94	101
Approximate weight of cable	kg/m	7500	8750	9900	11100	13450	15850	18550	21900
Minimum bending radius (static)	mm	800	850	900	950	1000	1100	1150	1250
Maximum pulling tension on cable	kg	1050	1425	1800	2250	2775	3600	4500	5000
Maximum DC resistance @20°C	Ω/km	0.2680	0.1930	0.1530	0.1240	0.0991	0.0754	0.0601	0.0470
Maximum AC resistance@ 90°C	Ω/km	0.3420	0.2470	0.1960	0.1590	0.1270	0.0976	0.0786	0.0625
Inductance	mH/km	0.371	0.353	0.338	0.327	0.319	0.306	0.294	0.285
Reactance@50Hz	Ω/km	0.117	0.111	0.106	0.103	0.100	0.096	0.092	0.089
Impedance @ 50Hz @ 90°C	Ω/km	0.361	0.27	0.233	0.19	0.163	0.137	0.122	0.11
Maximum Capacitance (C)	μF/km	0.232	0.259	0.282	0.303	0.323	0.359	0.401	0.442
Maximum charging current	A/km	0.63	0.71	0.77	0.83	0.88	0.98	1.09	1.2
Short circuit ratings									
1 second short circuit-rating of conductor (90 to 250°C)	kA	9.7	13.5	17.1	21	26.3	34.6	43.4	55.6
1 second short circuit-rating of metallic screen (80 to 200°C)	kA	9.7	13.5	15.7	16.6	22.1	23.6	25.7	27.6
Continuous current carrying capacity (as per conditions detailed below)									
Direct buried	Amps	255	300	340	380	430	490	540	590
Single way ducts	Amps	215	255	290	330	370	425	470	520
In air	Amps	270	330	375	430	490	570	650	700

The following conditions have been assumed to calculate the current ratings:

Directly buried in ground

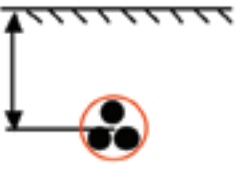

Laid in single way ducts

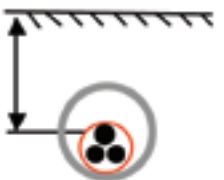

In air



- Thermal resistivity of soil = 1.2 K.m/W
- Ground temperature = 15°C
- Ambient air temperature = 25°C
- Depth of burial (to centre of cable, duct or trefoil group) = 800mm

Voltage 12/20 (22) kv Single Core copper unarmoured conductors

Typical technical data

Design Standards:
BS 7870-4.10
IEC 60502

Nominal cross-sectional area	mm ²	70	95	120	150	185	240	300	400	500	630	800	1000
Diameter over conductor	mm	9.8	11.5	12.8	14.3	15.9	18.4	20.5	23.2	26.2	30.3	34.7	38
Approximate diameter over insulation	mm	22	23.7	25	26.5	28.1	30.6	33.1	36.2	39.2	43.3	47.7	51.4
Approximate overall diameter	mm	28.5	30.3	32.1	33.6	35.5	38.1	41	44.4	47.8	52.3	57.1	61.4
Approximate weight of cable	kg/m	1270	1570	1860	2150	2520	3150	3820	4720	5790	7250	9090	11750
Minimum bending radius (static)	mm	700	700	750	800	800	850	900	1000	1050	1100	1250	1350
Maximum pulling tension on cable	kg	350	475	600	750	925	1200	1500	2000	2500	3150	4000	5000
Maximum DC resistance @20°C	Ω/km	0.268	0.193	0.153	0.124	0.0991	0.0754	0.0601	0.047	0.0366	0.0283	0.0221	0.0176
Maximum AC resistance@ 90°C	Ω/km	0.342	0.247	0.196	0.159	0.128	0.0977	0.0787	0.0627	0.0503	0.0408	0.0342	0.0295
Inductance	mH/km	0.429	0.407	0.39	0.377	0.369	0.352	0.337	0.326	0.316	0.305	0.291	0.283
Reactance@50Hz	Ω/km	0.135	0.128	0.123	0.119	0.116	0.111	0.106	0.102	0.099	0.096	0.091	0.089
Impedance @ 50Hz @ 90°C	Ω/km	0.368	0.278	0.231	0.198	0.172	0.148	0.132	0.12	0.111	0.104	0.098	0.094
Maximum capacitance (C)	μF/km	0.2	0.223	0.241	0.259	0.275	0.305	0.339	0.373	0.409	0.453	0.529	0.584
Maximum charging current	A/km	0.8	0.89	0.96	1.03	1.1	1.22	1.35	1.49	1.63	1.81	2.11	2.33
Short circuit ratings													
1 second short circuit-rating of conductor (90 to 250°C)	kA	9.7	13.5	17.1	21	26.3	34.6	43.4	55.6	72.1	90.7	115.1	143.8
1 second short circuit-rating of a 35mm ² Copper wire screen (80 to 250°C)	kA	4.8	4.8	4.8	4.8	4.8	4.8	4.8	4.8	4.8	4.8	4.8	4.8
1 second short circuit-rating of a 50mm ² Copper wire screen (80 to 250°C)	kA	8.2	8.2	8.2	8.2	8.2	8.2	8.2	8.2	8.2	8.2	8.2	8.2
Continuous current carrying capacity (as per conditions detailed below)													
Direct buried	Amps	270	320	360	410	460	530	600	690	760	850	930	1010
Single way ducts	Amps	270	320	360	405	445	520	570	630	700	780	860	920
In air	Amps	320	390	445	510	580	680	770	890	1020	1160	1290	1430

The following conditions have been assumed to calculate the current ratings:

Directly buried in ground

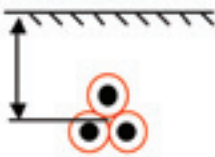

Laid in single way ducts

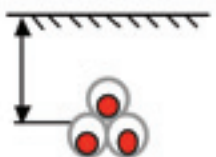

In air



- Cables laid in tight trefoil
- Thermal resistivity of soil = 1.2 K.m/W
- Ground temperature = 15°C
- Ambient air temperature = 25°C
- Depth of burial (to centre of cable, duct or trefoil group) = 800mm

Voltage 12/20 (22) kv Single Core armoured copper conductors

Typical technical data

Design Standards:
BS 6622
BS 7835

Nominal cross-sectional area	mm ²	70	95	120	150	185	240	300	400	500	630	800	1000
Diameter over conductor	mm	9.8	11.5	12.8	14.3	15.9	18.4	20.5	23.2	26.2	30.3	34.7	38
Approximate diameter over insulation	mm	22	23.7	25	26.5	28.1	30.6	33.1	36.2	39.2	43.3	47.7	51.4
Approximate overall diameter	mm	38	40	41	43	44	47	51	54	57	61	68	73
Approximate weight of cable	kg/m	2000	2400	2700	3050	3450	4150	5050	6000	7150	8750	10800	13050
Minimum bending radius (static)	mm	750	800	850	850	900	950	1050	1100	1150	1250	1350	1450
Maximum pulling tension on cable	kg	350	475	600	750	925	1200	1500	2000	2500	3150	4000	5000
Maximum DC resistance @20°C	Ω/km	0.2680	0.1930	0.1530	0.1240	0.0991	0.0754	0.0601	0.0470	0.0366	0.0283	0.0221	0.0176
Maximum AC resistance@ 90°C	Ω/km	0.3420	0.2470	0.1960	0.1590	0.1270	0.0976	0.0785	0.0624	0.0499	0.0403	0.0336	0.0288
Inductance	mH/km	0.454	0.432	0.413	0.400	0.390	0.372	0.362	0.349	0.338	0.326	0.310	0.301
Reactance@50Hz	Ω/km	0.143	0.136	0.130	0.126	0.123	0.117	0.114	0.110	0.106	0.103	0.097	0.095
Impedance @ 50Hz @ 90°C	Ω/km	0.371	0.281	0.235	0.203	0.177	0.152	0.138	0.126	0.117	0.11	0.103	0.099
Maximum capacitance (C)	μF/km	0.2	0.233	0.241	0.259	0.275	0.305	0.339	0.373	0.409	0.453	0.529	0.584
Maximum charging current	A/km	0.8	0.89	0.96	1.03	1.1	1.22	1.35	1.49	1.63	1.81	2.11	2.33
Short circuit ratings													
1 second short circuit-rating of conductor (90 to 250°C)	kA	9.7	13.5	17.1	21	26.3	34.6	43.4	55.6	>60	>60	>60	>60
1 second short circuit-rating of metallic screen (80 to 200°C)	kA	9.7	11.4	12	12.5	13	13.8	19.1	20.4	21.6	23.3	26.2	28.3
Continuous current carrying capacity (as per conditions detailed below)													
Direct buried	Amps	270	320	360	410	455	520	580	650	710	760	810	860
Single way ducts	Amps	260	300	340	370	400	450	490	530	570	610	670	700
In air	Amps	320	380	440	490	560	650	730	830	940	1050	1160	1260

The following conditions have been assumed to calculate the current ratings:

Directly buried in ground

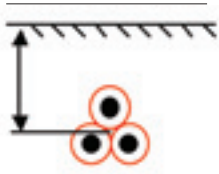

Laid in single way ducts

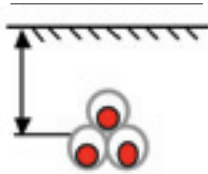

In air



- Cables laid in tight trefoil
- Thermal resistivity of soil = 1.2 K.m/W
- Ground temperature = 15°C
- Ambient air temperature = 25°C
- Depth of burial (to centre of cable, duct or trefoil group) = 800mm

Voltage 12/20 (22) kv Three Core armoured copper conductors

Typical technical data

Design Standards:
BS 6622
BS 7835

Nominal cross-sectional area	mm ²	3x70	3x95	3x120	3x150	3x185	3x240	3x300	3x400
Diameter over conductor	mm	9.8	11.5	12.8	14.3	15.9	18.4	20.5	23.2
Approximate diameter over insulation	mm	22	23.7	25	26.5	28.1	30.6	33.1	36.2
Approximate overall diameter	mm	71	75	80	83	87	92	99	106
Approximate weight of cable	kg/m	8200	9500	11500	12800	14350	16750	19450	22900
Minimum bending radius (static)	mm	850	900	1000	1000	1050	1150	1200	1300
Maximum pulling tension on cable	kg	1050	1425	1800	2250	2775	3600	4500	5000
Maximum DC resistance @20°C	Ω/km	0.2680	0.1930	0.1530	0.1240	0.0991	0.0754	0.0601	0.0470
Maximum AC resistance@ 90°C	Ω/km	0.3420	0.2470	0.1960	0.1590	0.1280	0.0981	0.0792	0.0633
Inductance	mH/km	0.388	0.369	0.353	0.342	0.333	0.319	0.306	0.296
Reactance@50Hz	Ω/km	0.122	0.116	0.111	0.107	0.105	0.100	0.096	0.093
Impedance @ 50Hz @ 90°C	Ω/km	0.363	0.273	0.225	0.192	0.165	0.14	0.125	0.112
Maximum capacitance (C)	μF/km	0.2	0.233	0.241	0.259	0.275	0.305	0.339	0.373
Maximum charging current	A/km	0.8	0.89	0.96	1.03	1.1	1.22	1.35	1.49
Short circuit ratings									
1 second short circuit-rating of conductor (90 to 250°C)	kA	9.7	13.5	17.1	21	26.3	34.6	43.4	55.6
1 second short circuit-rating of metallic screen (80 to 200°C)	kA	9.7	13.5	17.1	21	23.6	25	26.8	29
Continuous current carrying capacity (as per conditions detailed below)									
Direct buried	Amps	255	295	335	375	420	480	530	580
Single way ducts	Amps	225	260	300	335	380	430	480	530
In air	Amps	275	330	380	430	490	570	650	720

The following conditions have been assumed to calculate the current ratings:

Directly buried in ground

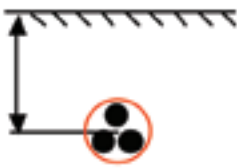

Laid in single way ducts

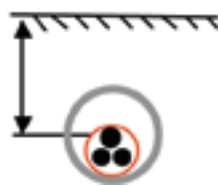

In air



- Thermal resistivity of soil = 1.2 K.m/W
- Ground temperature = 15°C
- Ambient air temperature = 25°C
- Depth of burial (to centre of cable, duct or trefoil group) = 800mm

Voltage 19/33 (36) kv Single Core unarmoured copper conductors

Typical technical data

Design Standards:
BS 7870-4.10
IEC 60502

Nominal cross-sectional area	mm ²	70	95	120	150	185	240	300	400	500	630	800	1000
Diameter over conductor	mm	9.8	11.5	12.8	14.3	15.9	18.4	20.5	23.2	26.2	30.3	34.7	38
Approximate diameter over insulation	mm	27	28.7	30	31.5	33.1	35.6	38.1	41.2	44.2	48.3	52.7	57.3
Approximate overall diameter	mm	34.1	36.1	37.5	39.3	41	43.8	46.6	50.2	53.4	58	66	71
Approximate weight of cable	kg/m	1560	1880	2160	2480	2860	3530	4220	5150	6250	7740	9630	12200
Minimum bending radius (static)	mm	340	360	380	390	420	440	470	500	540	580	660	710
Maximum pulling tension on cable	kg	350	475	600	750	925	1200	1500	2000	2500	3150	4000	5000
Maximum DC resistance @20°C	Ω/km	0.268	0.193	0.153	0.124	0.0991	0.0754	0.0601	0.047	0.0366	0.0283	0.0221	0.0176
Maximum AC resistance@ 90°C	Ω/km	0.342	0.247	0.196	0.159	0.128	0.098	0.079	0.063	0.051	0.042	0.035	0.03
Inductance	mH/km	0.46	0.437	0.4	0.38	0.37	0.36	0.36	0.33	0.32	0.31	0.3	0.29
Reactance@50Hz	Ω/km	0.144	0.137	0.131	0.127	0.124	0.118	0.114	0.109	0.106	0.102	0.097	0.094
Impedance @ 50Hz @ 90°C	Ω/km	0.371	0.282	0.236	0.204	0.178	0.153	0.138	0.126	0.117	0.11	0.102	0.098
Maximum capacitance (C)	μF/km	0.155	0.16	0.17	0.18	0.2	0.22	0.25	0.26	0.29	0.32	0.35	0.38
Maximum charging current	A/km	0.93	1.02	1.1	1.17	1.24	1.36	1.51	1.65	1.8	1.98	2.29	2.52
Short circuit ratings													
1 second short circuit-rating of conductor (90 to 250°C)	kA	9.7	13.5	17.1	21	26.3	34.6	43.4	57.7	72.1	90.7	115.1	143.8
1second short circuit-rating of a 35mm ² Copper wire screen (80 to 250°C)	kA	4.8	4.8	4.8	4.8	4.8	4.8	4.8	4.8	4.8	4.8	4.8	4.8
1 second short circuit-rating of a 50mm ² Copper wire screen (80 to 250°C)	kA	8.2	8.2	8.2	8.2	8.2	8.2	8.2	8.2	8.2	8.2	8.2	8.2
Continuous current carrying capacity (as per conditions detailed below)													
Direct buried	Amps	270	320	360	410	460	530	600	690	760	850	930	1010
Single way ducts	Amps	270	320	360	405	445	520	570	630	700	780	860	920
In air	Amps	320	390	445	510	580	680	770	890	1020	1160	1290	1430

The following conditions have been assumed to calculate the current ratings:

Directly buried in ground

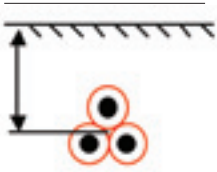

Laid in single way ducts

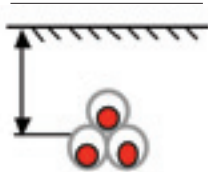

In air



- Cables laid in tight trefoil
- Thermal resistivity of soil = 1.2 K.m/W
- Ground temperature = 15°C
- Ambient air temperature = 25°C
- Depth of burial (to centre of cable, duct or trefoil group) = 800mm

Voltage 19/33 (36) kv Single Core unarmoured aluminium conductors

Typical technical data

Design Standards:
BS 7870-4.10
IEC 60502

Nominal cross-sectional area	mm ²	70	95	120	150	185	240	300	400	500	630	800	1000
Diameter over conductor	mm	9.8	11.5	12.8	14.3	15.9	18.4	20.5	23.2	26.2	30.3	34.7	38
Approximate diameter over insulation	mm	27	28.7	30	31.5	33.1	35.6	38.1	41.2	44.2	48.3	52.7	57.3
Approximate overall diameter	mm	34.1	36.1	37.5	39.3	41	43.8	46.6	50.2	53.4	58	66	71
Approximate weight of cable	kg/m	1550	1750	1850	2000	2200	2500	2800	3200	3600	4200	5050	6000
Minimum bending radius (static)	mm	800	850	850	900	950	1000	1050	1100	1150	1250	1350	1450
Maximum pulling tension on cable	kg	210	285	360	450	555	720	900	1200	1500	1890	2400	3000
Maximum DC resistance @20°C	Ω/km	0.443	0.32	0.253	0.206	0.164	0.125	0.1	0.0778	0.0605	0.0469	0.0367	0.0291
Maximum AC resistance@ 90°C	Ω/km	0.568	0.411	0.325	0.265	0.211	0.161	0.129	0.101	0.0778	0.0629	0.0367	0.0291
Inductance	mH/km	0.46	0.437	0.419	0.406	0.391	0.374	0.361	0.348	0.337	0.325	0.308	0.299
Reactance@50Hz	Ω/km	0.144	0.137	0.131	0.127	0.123	0.117	0.114	0.109	0.106	0.102	0.097	0.094
Impedance @ 50Hz @ 90°C	Ω/km	0.586	0.433	0.35	0.294	0.244	0.199	0.172	0.149	0.132	0.12	0.109	0.103
Maximum capacitance (C)	μF/km	0.155	0.17	0.183	0.196	0.211	0.232	0.252	0.275	0.3	0.33	0.383	0.421
Maximum charging current	A/km	0.93	1.02	1.1	1.17	1.26	1.39	1.51	1.65	1.8	1.98	2.29	2.52
Short circuit ratings													
1 second short circuit-rating of conductor (90 to 250°C)	kA	6.4	8.9	11.3	13.9	17.4	22.9	28.7	36.8	46.4	59.9	>60	>60
1 second short circuit-rating of a 35mm ² Copper wire screen (80 to 250°C)	kA	4.8	4.8	4.8	4.8	4.8	4.8	4.8	4.8	4.8	4.8	4.8	4.8
1 second short circuit-rating of a 50mm ² Copper wire screen (80 to 250°C)	kA	8.2	8.2	8.2	8.2	8.2	8.2	8.2	8.2	8.2	8.2	8.2	8.2
Continuous current carrying capacity (as per conditions detailed below)													
Direct buried	Amps	210	250	280	320	360	415	475	550	610	690	780	860
Single way ducts	Amps	210	250	280	320	350	415	460	520	570	650	770	800
In air	Amps	250	305	345	400	450	530	600	700	820	940	1070	1210

The following conditions have been assumed to calculate the current ratings:

Directly buried in ground

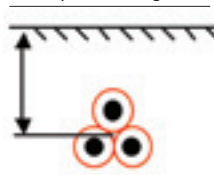

Laid in single way ducts

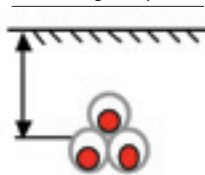

In air

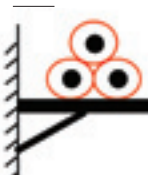

- Cables laid in tight trefoil
- Thermal resistivity of soil = 1.2 K.m/W
- Ground temperature = 15°C
- Ambient air temperature = 25°C
- Depth of burial (to centre of cable, duct or trefoil group) = 800mm

Voltage 19/33 (36) kv Single Core armoured copper conductors

Typical technical data

Design Standards:
BS 6622
BS 7835

Nominal cross-sectional area	mm ²	70	95	120	150	185	240	300	400	500	630	800	1000
Diameter over conductor	mm	9.8	11.5	12.8	14.3	15.9	18.4	20.5	23.2	26.2	30.3	34.7	38
Approximate diameter over insulation	mm	27	28.7	30	31.5	33.1	35.6	38.1	41.2	44.2	48.3	52.7	57.3
Approximate overall diameter	mm	43	45	47	50	51	54	57	60	63	67	74	79
Approximate weight of cable	kg/m	2450	2800	3150	3650	4150	4800	5600	6600	7800	9400	11550	13850
Minimum bending radius (static)	mm	900	900	950	1000	1050	1100	1150	1200	1300	1350	1500	1600
Maximum pulling tension on cable	kg	350	475	600	750	925	1200	1500	2000	2500	3150	4000	5000
Maximum DC resistance @20°C	Ω/km	0.2680	0.1930	0.1530	0.1240	0.0991	0.0754	0.0601	0.0470	0.0366	0.0283	0.0221	0.0176
Maximum AC resistance@ 90°C	Ω/km	0.3420	0.2470	0.1960	0.1590	0.1270	0.0974	0.0783	0.0622	0.0496	0.0399	0.0331	0.0284
Inductance	mH/km	0.482	0.458	0.439	0.431	0.420	0.400	0.383	0.369	0.357	0.344	0.327	0.317
Reactance@50Hz	Ω/km	0.152	0.144	0.138	0.135	0.132	0.126	0.120	0.116	0.112	0.108	0.103	0.099
Impedance @ 50Hz @ 90°C	Ω/km	.379.374	0.286	0.239	0.209	0.183	0.159	0.144	0.132	0.123	0.115	0.108	0.103
Maximum capacitance (C)	μF/km	0.155	0.17	0.183	0.196	0.207	0.228	0.252	0.275	0.3	0.33	0.383	0.421
Maximum charging current	A/km	0.93	1.02	1.1	1.17	1.24	1.36	1.51	1.65	1.8	1.98	2.29	2.52
Short circuit ratings													
1 second short circuit-rating of conductor (90 to 250°C)	kA	9.7	13.5	17.1	21	26.3	34.6	43.4	55.6	>60	>60	>60	>60
1 second short circuit-rating of metallic screen (80 to 200°C)	kA	9.7	13.3	13.8	18.3	19.1	20	21.2	22.5	24.2	25.8	28.7	30.8
Continuous Current Carrying Capacity (as per conditions detailed below)													
Direct buried	Amps	270	320	360	410	455	520	580	650	710	760	810	860
Single way ducts	Amps	260	300	340	370	400	450	490	530	570	610	670	700
In air	Amps	320	380	440	490	560	650	730	830	940	1050	1160	1260

The following conditions have been assumed to calculate the current ratings:

Directly buried in ground

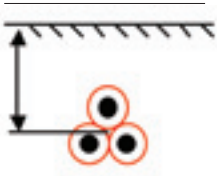

Laid in single way ducts

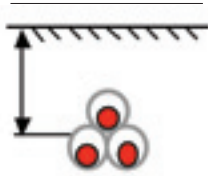

In air



- Cables laid in tight trefoil
- Thermal resistivity of soil = 1.2 K.m/W
- Ground temperature = 15°C
- Ambient air temperature = 25°C
- Depth of burial (to centre of cable, duct or trefoil group) = 800mm

Voltage 19/33 (36) kv Three Core armoured copper conductors

Typical technical data

Design Standards:

BS 6622

BS 7835

Nominal cross-sectional area	mm ²	3x70	3x95	3x120	3x150	3x185	3x240	3x300	3x400
Diameter over conductor	mm	9.8	11.5	12.8	14.3	15.9	18.4	20.5	23.2
Approximate diameter over insulation	mm	27	28.7	30	31.5	33.1	35.6	38.1	41.2
Approximate overall diameter	mm	75	79	83	86	89	95	101	108
Approximate weight of cable	kg/m	6400	7550	8550	9600	11000	13200	15600	18650
Minimum bending radius (static)	mm	1150	1200	1250	1300	1350	1450	1550	1650
Maximum pulling tension on cable	kg	1050	1425	1800	2250	2775	3600	4500	5000
Maximum DC resistance @20°C	Ω/km	0.2680	0.1930	0.1530	0.1240	0.0991	0.0754	0.0601	0.0470
Maximum AC resistance@ 90°C	Ω/km	0.3420	0.2470	0.1960	0.1590	0.1280	0.0978	0.0788	0.0629
Inductance	mH/km	0.427	0.405	0.387	0.375	0.365	0.348	0.333	0.321
Reactance@50Hz	Ω/km	0.134	0.127	0.122	0.118	0.115	0.109	0.105	0.101
Impedance @ 50Hz @ 90°C	Ω/km	0.367	0.277	0.23	0.198	0.172	0.147	0.131	0.119
Maximum capacitance (C)	μF/km	0.155	0.17	0.183	0.196	0.207	0.228	0.252	0.275
Maximum charging current	A/km	0.93	1.02	1.1	1.17	1.24	1.36	1.51	1.65
Short circuit ratings									
1 second short circuit-rating of conductor (90 to 250°C)	kA	9.7	13.5	17.1	21	26.3	34.6	43.4	55.6
1 second short circuit-rating of metallic screen (80 to 200°C)	kA	4.6	4.6	5	5	5.3	5.7	6.1	6.5
Continuous current carrying capacity (as per conditions detailed below)									
Direct buried	Amps	255	295	335	375	420	490	550	610
Single way ducts	Amps	230	260	305	335	380	435	490	550
In air	Amps	290	330	390	440	500	580	660	730

The following conditions have been assumed to calculate the current ratings:

Directly buried in ground

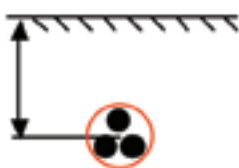

Laid in single way ducts

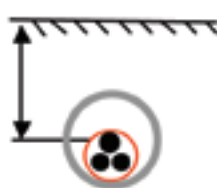

In air



- Thermal resistivity of soil = 1.2 K.m/W
- Ground temperature = 15°C
- Ambient air temperature = 25°C
- Depth of burial (to centre of cable, duct or trefoil group) = 800mm

Notes

Notes

Notes

With energy as the basis of its development, Nexans, the worldwide leader in the cable industry, offers an extensive range of cables and cabling systems, The Group is a global player in the infrastructure, industry, building and Local Area Network markets. Nexans addresses a series of market segments from energy, transport and telecom networks to shipbuilding, oil and gas, nuclear power, automotive, electronics, aeronautics, handling and automation. With an industrial presence in 39 countries and commercial activities worldwide, Nexans employs 23, 500 people and had sales in 2008 of 6.8 billion Euros.



Nexans Energy Networks

Nexans House, Chesney Wold, Bleak Hall, Milton Keynes MK6 1LA

Tel: 01908 250840 Fax: 01908 250841 Email: sales.energynetworks@nexans.com

www.nexans.co.uk