

CAUTION : Read instructions thoroughly and completely prior to beginning installation.

Installation Instructions

PITO-E

Plug-in termination - Type A interface

For indoor and outdoor applications

CONTENTS :	1 - Plug-in Terminator	2 - Nylon bail legs
	1 - Nylon rod	2 - Nylon nuts
	1 - Installation instructions	2 - Screws
	- Silicone grease and wipers	2 - Rivets

For NF C 52-053 bushing fixing system

Fig. 1

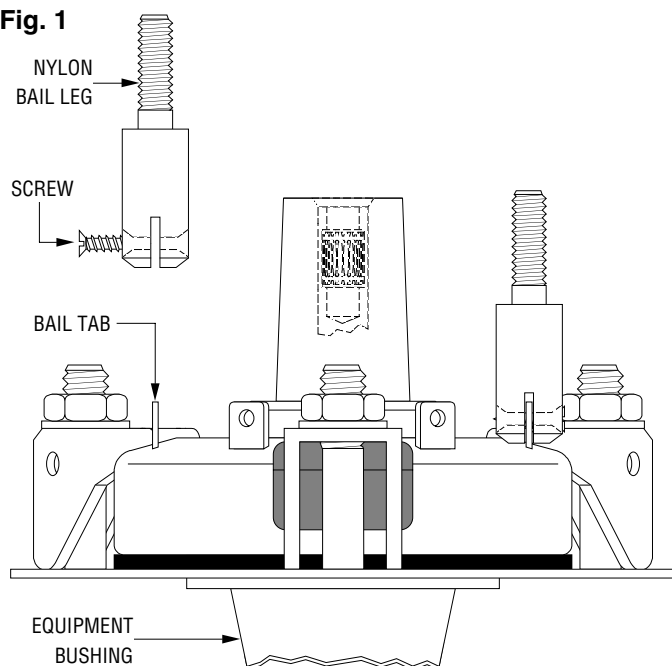
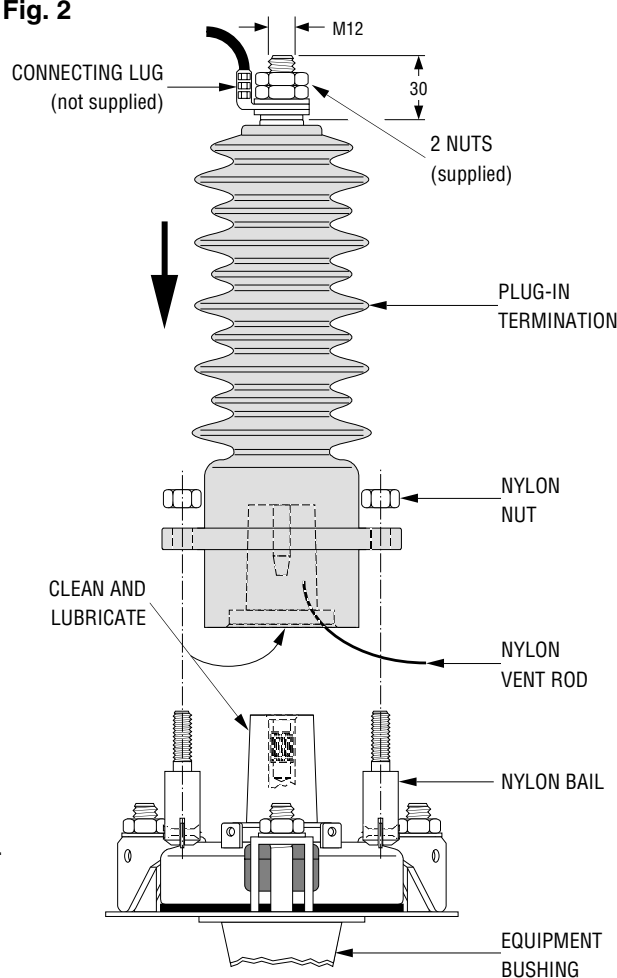

Fig. 2



1. Install the nylon bail legs on the bushing tabs (Fig. 1).
2. Using a screwdriver, install the screws as shown (Fig. 1).
3. Thoroughly clean the mating interfaces of both bushing and plug-in termination (Fig. 2).
4. Using silicone grease supplied, lubricate* both interfaces.
5. Insert nylon vent rod into the entrance portion of the plug-in termination.
6. Push down hard plug-in termination on to the bushing.
7. **Remove nylon vent rod.**
8. Install the nuts on the bail legs and tighten.
Tighten exerting 1 Nm (0,1 kgm or 0,72 foot-pounds) of torque.
9. Connect cable to the threaded stud of the plug-in termination.

*** USE ONLY THE SILICONE LUBRICANT SUPPLIED**

90082E-RV/3-A

This product should be installed only by competent personnel trained in good safety practices involving high voltage electrical equipment. These instructions are not intended as a substitute for adequate training or experience in such safety practices. These instructions do not attempt to provide for every possible contingency.

Failure to follow these instructions could result in damage to the product and serious or fatal injury.

IMPORTANT : Cable and associated apparatus must be de-energised, locked out, and tagged prior to product installation.

FOR INFORMATION ONLY Please always use the instructions supplied in the kit

For DIN 42 538 bushing fixing system

Fig. 1

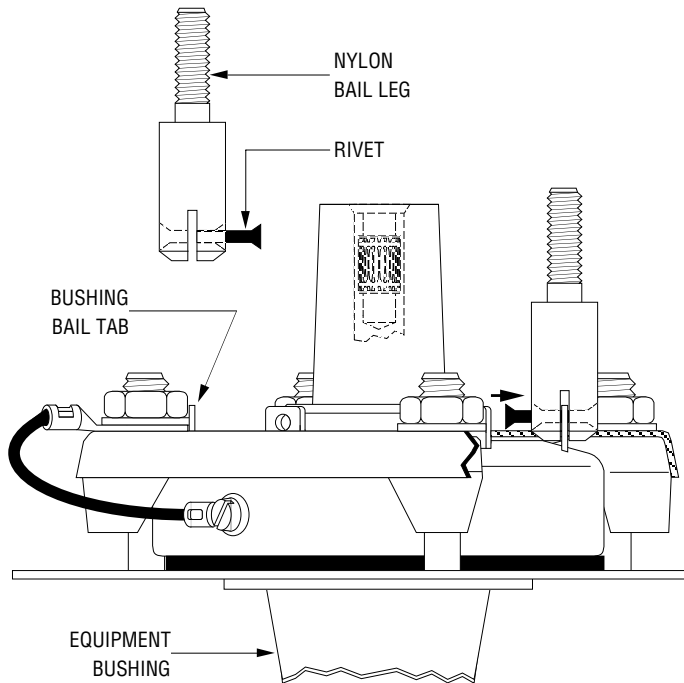
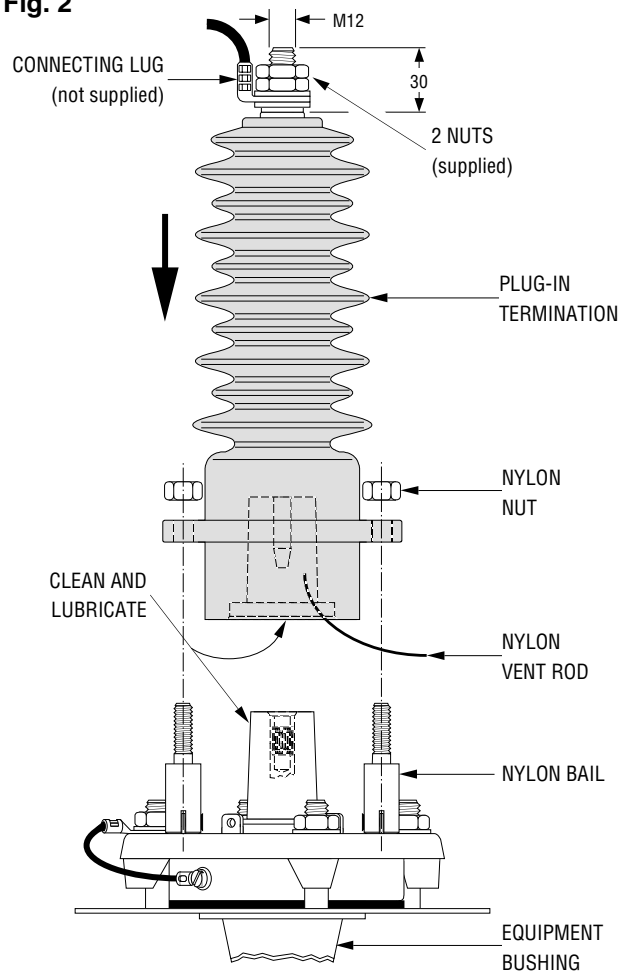

Fig. 2



1. Install the nylon bail legs on the bushing tabs (Fig. 1).
2. Using the supplied rivets, secure the nylon bail legs on the bushing tabs (Fig. 1).
3. Thoroughly clean the mating interfaces of both bushing and plug-in termination (Fig. 2).
4. Using silicone grease supplied, lubricate* both interfaces.
5. Insert nylon vent rod into the entrance portion of the plug-in termination.
6. Push down hard plug-in termination on to the bushing.
7. **Remove nylon vent rod.**
8. Install the nuts on the bail legs and tighten. Tighten exerting 1 Nm (0,1 kgm or 0,72 foot-pounds) of torque.
9. Connect cable to the threaded stud of the plug-in termination.

* USE ONLY THE SILICONE LUBRICANT SUPPLIED

Euromold
a Nexans company

EUROMOLD N.V.
Zuid III - Industrielaan 12
B-9320 EREMBODEGEM-AALST – BELGIUM
Tel: +32 (0)53/85 02 11 – Telefax: +32 (0)53/83 10 13

FOR INFORMATION ONLY Please always use the instructions supplied in the kit